

- en
- fr
- de
- nl
- es
- pt
- it
- el
- tr



Digital recipe book
Livre de recettes digital
Livro de receitas digital
Digitales Kochbuch

EASY FRY™ XL SURFACE

www.tefal.com
www.moulinex.com

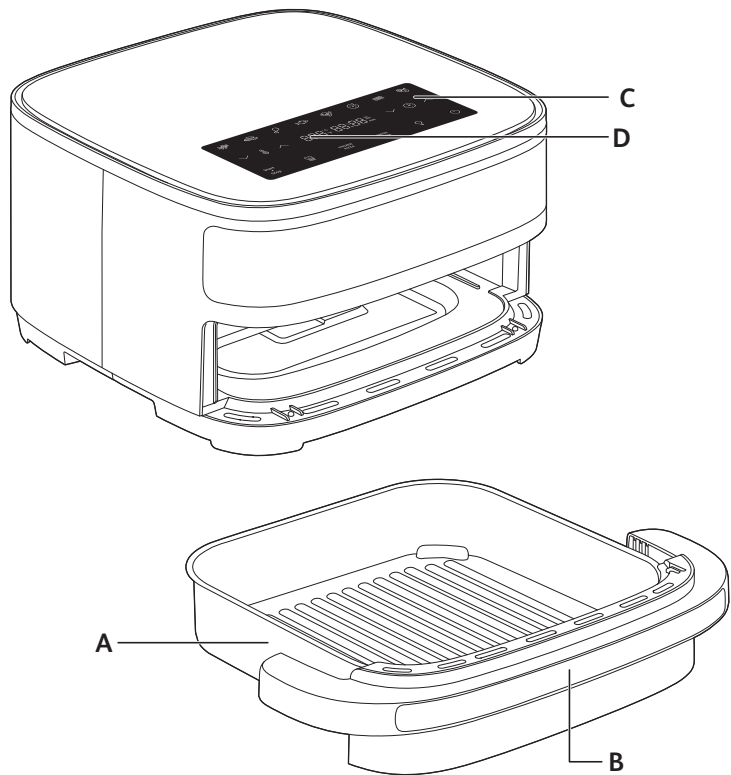

DESCRIPTION

- A. Bowl
- B. Bowl handle

- C. Digital touchscreen panel
- D. Time/temperature display

AUTOMATIC COOKING MODES

- | | |
|--------------------|------------------------------|
| Fries | Cookies |
| Nuggets | Bacon / Beef bacon |
| Chicken drumsticks | Dehydration |
| Fish | FROZEN PIZZA
Frozen pizza |
| Vegetables | FRESH PIZZA
Fresh pizza |

BEFORE FIRST USE

Read the safety instructions and manual first and keep them in a safe place.

1. Remove all packaging material and any stickers from the appliance.
2. Thoroughly clean the bowl with hot water, some washing-up liquid and a non-abrasive sponge.

Note: the bowl is dishwasher safe.

3. Wipe the inside and outside of the appliance with a damp cloth. The appliance works by producing hot air. Do not fill the bowl (A) with oil or frying fat.

PREPARING FOR USE

1. Place the appliance on a flat, stable, heat-resistant work surface away from water splashes.
2. **Do not fill the bowl with oil or any other liquid.**
Do not put anything on top of the appliance. This disrupts the airflow and affects the hot air frying result.

IMPORTANT: To prevent the appliance from overheating, do not place it in a corner or below a wall cupboard. A gap of at least 15cm should be left around the appliance to allow air to circulate.











USING THE APPLIANCE

The appliance can cook a large range of recipes. Cooking times for the main types of food are given in the section 'Cooking Guide'. Online recipes help you get to know the appliance.











1. Connect the power supply cord to an electrical socket.
2. Place the food in the bowl.

Note: Never fill the bowl beyond the MAX level mark or exceed the maximum amount indicated in the table (see into section 'Cooking Guide'), as this could affect the quality of the end result.







3. Slide the bowl back into the appliance.
4. To begin cooking, you can select one of the automatic mode.

- Press  button to display the cooking mode.
 - Then press  button on the screen to select the desired cooking mode (these modes are described in detail in the “Cooking guide” section).
 - If needed, adjust the cooking time  by pressing the  and  buttons. The timer can be set for between 0 and 60 minutes.
 - You can also adjust the temperature  with  and  buttons on the digital screen. The thermostat varies from 40-230°C.
 - Confirm the cooking mode by pressing the  button. This will launch the cooking process.
 - Cooking starts. The selected temperature and remaining cooking time appear on the on-screen display.
5. During cooking, the inner light allows the checking of the cooking's process. Press  to light up. Press again to turn off.
 6. Some food will require shaking halfway through the cooking time (see section ‘Cooking Guide’). To shake the food, pull the bowl out of the appliance by the handle and shake it. Then slide the bowl back into the appliance, the appliance restarts automatically.
 7. When you hear the timer sound, the cooking time set has finished. Pull the bowl out of the appliance and place it on a heat-resistant surface.
 8. Check if the food is ready.
If the food is not ready yet, simply slide the bowl back into the appliance and set the timer for a few extra minutes.
 9. When the food is cooked, take out the bowl. To remove food, use a pair of tongs to lift the food out of the bowl.
Caution: After hot air frying, the bowl, and the food are very hot. Do not touch the bowl during use and for some time after use, as it gets very hot. Only hold the bowl by the handle with both hands.
 10. When a batch of food is ready, the appliance is instantly ready for preparing another batch of food.

PIZZA

1. Place the pizza in the bowl and slide the bowl back into the appliance.
2. Press , then press  or .
3. If needed, adjust the time  by pressing  and  buttons on the digital screen. You can also adjust the temperature  with  and  buttons on the digital screen.
4. Press  to launch the cooking. The selected temperature and remaining cooking time appear on the screen display.
5. When you hear the timer sound, the cooking has finished. Take the bowl out the appliance and place it on a heat-resistant surface.
6. Check if the food is ready. If the food is not ready yet, put it back on the appliance and set the timer for a few extra minutes.
7. When the food is cooked, take out the bowl.
Caution : After hot frying, the bowl and the food are very hot. Do not touch the bowl during use and for some time after use, as it gets very hot. Only hold the bowl by the handle with both hands.

DEHYDRATION

1. Place the ingredients in the bowl and slide the bowl back into the appliance.
2. Press , then adjust the temperature  by pressing  button to 70°C on the digital screen.
3. Then set the desired cooking time  by pressing  and  button. You can set the timing from 1 hour to 12 hours.
4. Press the Start button  to launch the dehydration process. The selected temperature and remaining cooking time appear on the screen display.
5. When you hear the timer sound, the cooking has finished. Take the bowl out the appliance and place it on a heat-resistant surface.
6. Check if the food is ready. If the food is not ready yet, put it back on the appliance and set the timer for a few extra minutes.
7. When the food is cooked, take out the bowl. To remove food, use a pair of tongs to lift the food out the bowl.
Caution : After hot frying, the bowl, and the food are very hot. Do not touch the bowl during use and for some time after use, as it gets very hot. Only hold the bowl by the handle with both hands.













COOKING GUIDE



























The table below helps you to select the basic settings for the food you want to prepare.

Note: The cooking times below are only a guide and may vary according to the variety and batch of potatoes used. For other food the size, shape and brand may affect results. Therefore, you may need to adjust the cooking time slightly.

NOTE for Potatoes and French fries

- Limit the frying temperature at 180°C.
- Control the cooking. Do not eat burnt food.
- We advise frying to a slightly golden color instead of brown color.
- Store your fresh potatoes in a room above 8°C
- Before cooking, soak the fresh potatoes for 20 minutes to reduce the amount of starch.

						
Potatoes & fries						
Frozen chips (10 mm x 10 mm standard thickness)	1000 g		35 min	180°C		2 shakes
Homemade Fries (8 x 8 mm)	1000 g		35 min	180°C		1 tbsp of oil + 2 shakes
Frozen potato wedges	1000 g		35 min	180°C		1 tbsp of oil + 2 shakes

						
Meat & Poultry						
Chicken breast fillets (boneless)	500 - 900 g		20 - 25 min	180°C		Turn halfway through cooking
Chicken drumsticks	1500 g (12 pcs)		25 min	200°C		
Bacon / Beef bacon	8 slices		8 min	180°C		
Sausage	10 pieces		25 min	200°C		Turn halfway through cooking
Fish						
Salmon fillet	6 pcs (150g/ piece)		8 min	200°C		
Prawns	12 pieces		7 min	140°C		
Snacks						
Frozen chicken nuggets	700 g		15 min	200°C		
Frozen chicken wings	800 g		16 min	200°C		
Frozen cheese sticks	750 g		16 min	200°C		
Frozen pizza	26cm diameter	FROZEN PIZZA	10 min	200°C		
Fresh pizza		FRESH PIZZA	6 min	220°C		
Homemade pizza		FRESH PIZZA	10 min	200°C		
Vegetables						
Nems	18 pcs (900 g)		10 min	200°C		
Cauliflower (tops)	800 g		20 min	180°C		
Zucchini	600 g		10 min	200°C		
Baking						
Cookies	9 pieces		9-11 min	180°C		
Dehydration						
Sliced apples	1-2 pieces		4 h	70°C		

* Shake halfway through cooking.

IMPORTANT: To avoid damaging your appliance, never exceed the maximum quantities of ingredients and liquids indicated in the instruction manual and in the recipes. When you use mixtures that rise (such as with cake, quiche or muffins) the oven dish should not be filled more than halfway.

TIPS

- Smaller food usually requires a slightly shorter cooking time than larger size foods.
- Shaking food halfway through the cooking time improves the end result and can help prevent uneven cooking.
- To make your fresh potatoes extra crispy, try adding a small amount of oil before cooking and shake to evenly cover. We recommend 14ml of oil. Do not add oil to frozen potatoes.
- Snacks that can be cooked in an oven can also be cooked in the appliance.
- The optimal recommended quantity for cooking fries is 700 grams.
- Use ready made puff and shortcrust pastry to make filled snacks quickly and easily.
- Place an oven dish in the appliance's bowl if you want to bake a cake or quiche or if you want to fry delicate ingredients or filled ingredients. You can use an oven dish in silicon, stainless steel, aluminium, terracotta.
- You can also use the appliance to reheat food. To reheat food, set the temperature to 160°C for up to 10 minutes. Cooking time could be adjusted depending on food quantity in order to fully reheat the food.

MAKING HOME-MADE CHIPS

If you want to make home-made chips, follow the steps below.

1. Choose a variety of potato recommended for making chips. Peel the potatoes and cut them into equal thickness chips.
2. Soak the potato chips in cold water for at least 20 minutes, drain them and dry them with a clean, highly absorbent tea towel. Then pat with paper kitchen towel. The chips must be thoroughly dry before cooking.
3. Pour 1 tablespoon of oil (vegetable, sunflower or olive) in a dry bowl, put the chips on top and mix until they are coated with oil.
4. Remove the chips from the bowl with your fingers or a kitchen utensil so that any excess oil stays behind in the bowl. Place the chips in the bowl.
Note: Do not tip the container of oil coated chips directly into the bowl in one go, otherwise excess oil will end up at the bottom of the bowl.
5. Fry the chips according to the instructions in the section Cooking guide.

CLEANING

Clean the appliance after every use.

The bowl has a non-stick coating. Do not use metal kitchen utensils or abrasive cleaning materials to clean it, as this may damage the nonstick coating.

1. Remove the mains plug from the wall socket and let the appliance cool down.
Note: Remove the bowl to let the appliance cool down more quickly.
2. Wipe the outside of the appliance with a damp cloth.
3. Clean the bowl with hot water, some washing-up liquid and a non-abrasive sponge. You can use a degreasing liquid to remove any remaining dirt.

Note: the bowl is dishwasher safe.

- Tip: If food debris/residue is stuck at the bottom of the bowl, fill them with hot water and some washing-up liquid. Let the bowl soak for approximately 10 minutes. Then rinse clean and dry.
4. Clean the heating element with a dry, cleaning brush to remove any food residues.
 5. Do not immerse the appliance in water or any other liquid.

STORAGE

1. Unplug the appliance and let it cool down.
2. Make sure all parts are clean and dry.

GUARANTEE AND SERVICE

If you need service or information or if you have a problem, please visit the brand website or contact the brand Consumer Care Centre in your country. You can find the phone number in the worldwide guarantee leaflet. If there is no Consumer Care Centre in your country, go to your local dealer.

TROUBLESHOOTING



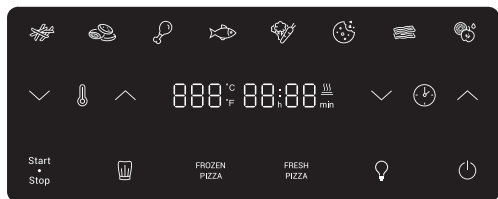
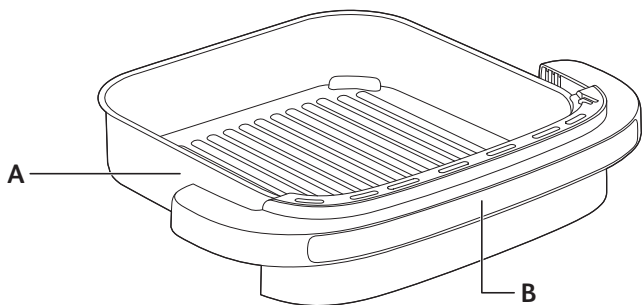
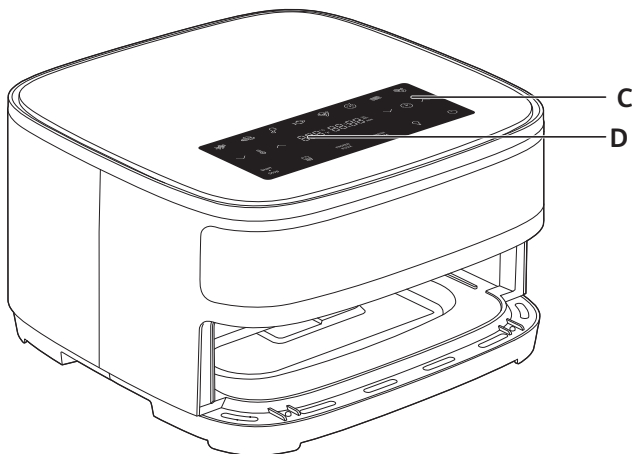







If you encounter problems with the appliance, visit the brand website (see cover page on this document) for a list of frequently asked questions or contact the Consumer Care Centre in your country.



DESCRIPTION

- A. Cuve
- B. Poignée de la cuve
- C. Ecran numérique tactile
- D. Affichage temps de cuisson/température

MODES DE CUISSON AUTOMATIQUES

-  Frites
-  Nuggets
-  Ailes / Pilons de poulet
-  Poisson
-  Légumes
-  Cookies
-  Bacon / Bacon de boeuf
-  Déshydratation
-  Pizza surgelée
-  Pizza fraîche / maison

AVANT LA PREMIÈRE UTILISATION

Lisez attentivement les consignes de sécurité et le mode d'emploi et conservez-les soigneusement.

1. Retirez tout le matériel d'emballage et enlevez les autocollants de l'appareil.
2. Nettoyez bien la cuve à l'eau chaude, avec du détergent à vaisselle et une éponge non abrasive.
Remarque : la cuve est lavable au lave-vaisselle.
3. Essuyez l'intérieur et l'extérieur de l'appareil avec un chiffon humide. L'appareil fonctionne à l'air chaud. Ne remplissez pas la cuve avec de l'huile ou de la graisse de friture.

PRÉPARATION À L'UTILISATION









1. Placez l'appareil sur une surface stable, horizontale, résistante à la chaleur et à l'abri des projections d'eau.
2. **Ne remplissez pas la cuve avec de l'huile ou tout autre liquide.**
Ne posez rien sur l'appareil. Cela perturbe le débit d'air et nuit au résultat de la friture à air chaud.

IMPORTANT : Pour éviter que l'appareil ne surchauffe, ne le placez pas dans un coin ou sous un placard. Un espace de 15 cm minimum doit être laissé autour de l'appareil pour permettre à l'air de circuler.

MODE D'EMPLOI DE L'APPAREIL

L'appareil permet de cuire une vaste gamme de recettes. Les temps de cuisson pour les principaux ingrédients sont indiqués dans la section « Réglages ». Vous trouverez plus de recettes sur le site de marque.

1. Insérez la fiche secteur sur une prise murale.
2. Retirez délicatement la cuve de l'appareil et mettez-y les ingrédients.
Remarque : Ne remplissez jamais la cuve au-delà de l'indication MAX et ne dépassez jamais la quantité indiquée dans le tableau (voir la section « Réglages »), car cela pourrait nuire à la qualité du résultat final.
3. Remettez la cuve dans l'appareil.
4. Pour lancer votre cuisson, sélectionnez un mode de cuisson automatique.











- Appuyez sur  pour afficher les modes de cuisson
- Appuyez sur  jusqu'à choisir le menu automatique souhaité (explication des modes dans la section « Réglages »).
- Il est possible d'ajuster le temps de cuisson en appuyant sur la touche  et en réglant avec  et  de l'écran numérique. La minuterie va de 0 à 60 minutes.
- Vous pouvez ajuster la température  en appuyant sur les boutons  and  de l'écran numérique. Le thermostat varie de 40 à 230°C.
- Appuyez sur le bouton  pour lancer la cuisson avec la température et le temps sélectionnés.
- La cuisson commence. La température sélectionnée et le temps de cuisson restent paraissent en alternance à l'écran.

5. Pendant la cuisson, la lumière intérieure permet de contrôler l'avancée de la cuisson. Appuyez sur  pour allumer. Appuyez de nouveau pour éteindre.
6. Certains ingrédients doivent être remués à mi-cuisson (voir la section « Réglages »). Pour remuer les ingrédients, retirez la cuve de l'appareil en la tenant par la poignée et secouez. Ensuite, remettez la cuve en place dans l'appareil, l'appareil se relance automatiquement.
7. Lorsque le temps de cuisson est écoulé, l'appareil sonne et s'arrête. Retirez la cuve de l'appareil et posez-la sur une surface résistante à la chaleur.
8. Vérifiez si les ingrédients sont prêts.

Si les ingrédients ne sont pas encore prêts, réinsérez simplement la cuve dans l'appareil et réglez la minuterie à quelques minutes supplémentaires.

9. Lorsque les ingrédients sont prêts, retirez la cuve et utilisez une pince pour retirer les ingrédients.
Attention : Après la cuisson à air chaud, la cuve, et les ingrédients sont chauds. Ne touchez pas la cuve pendant et après l'utilisation lorsqu'elle est encore chaude. Tenez toujours la cuve par la poignée à l'aide des deux mains.
10. Lorsqu'un lot d'ingrédients est prêt, l'appareil est prêt instantanément pour préparer un autre lot.

PIZZA

1. Placez la pizza dans la cuve et la cuve dans l'appareil.
2. Appuyez sur , ensuite appuyez sur la touche  ou .
3. Si besoin, ajustez le temps de cuisson  en appuyant sur les touches  et  de l'écran digital. Vous pouvez aussi ajuster la température  avec les touches  et .
4. Appuyez sur le bouton  pour lancer la cuisson. La température et le temps restant s'affichent à l'écran.
5. Lorsque le temps de cuisson est écoulé, l'appareil sonne et s'arrête. Retirez la cuve de l'appareil et posez-la sur une surface résistante à la chaleur.
6. Vérifiez si les ingrédients sont prêts.

Si les ingrédients ne sont pas encore prêts, réinsérez simplement la cuve dans l'appareil et réglez quelques minutes supplémentaires.

Attention : Après la cuisson à air chaud, la cuve, et les ingrédients sont chauds. Ne touchez pas la cuve pendant et après l'utilisation lorsqu'elle est encore chaude. Tenez toujours la cuve par la poignée à l'aide des deux mains.

DÉSHYDRATATION

1. Retirez délicatement la cuve de l'appareil et mettez-y les ingrédients. Remettez la cuve dans l'appareil.
2. Appuyez sur ensuite réglez la température en appuyant sur le bouton jusque 70°C.
3. Réglez ensuite le temps de cuisson souhaité en appuyant sur les boutons et de l'écran numérique. La minuterie en mode déshydratation va de 1 à 12 heures.
4. Appuyez sur le bouton de démarrage pour lancer la déshydratation. La température sélectionnée et le temps de cuisson restant paraissent à l'écran.
5. Lorsque le temps est écoulé, l'appareil sonne et s'arrête. Retirez la cuve de l'appareil et la poser sur une surface résistante à la chaleur.
6. Vérifiez si les ingrédients sont prêts. Si les ingrédients ne sont pas encore prêts, réinsérez simplement la cuve dans l'appareil et réglez la minuterie sur quelques minutes supplémentaires.
7. Lorsque les ingrédients sont prêts, retirez la cuve et utilisez une pince pour retirer les ingrédients.

Attention : Après la cuisson à air chaud, la cuve, et les ingrédients sont chauds. Ne touchez pas la cuve pendant et après l'utilisation lorsqu'elle est encore chaude. Tenez toujours la cuve par la poignée à l'aide des deux mains.

RÉGLAGES

Le tableau ci-dessous vous aide à sélectionner les réglages de base pour les ingrédients que vous souhaitez préparer. **Remarque : les temps de cuisson ne sont fournis qu'à titre de référence et diffèrent selon la variété et la quantité de pommes de terre. Pour les autres aliments, les résultats varient en fonction de leur grosseur, de leur forme et de leur marque. Il est donc possible que vous ayez à modifier légèrement le temps de cuisson.**

REMARQUE pour les pommes de terre et les frites

- Limitez la température de friture à 180°C.
- Contrôler la cuisson. Ne mangez pas de nourriture brûlée.
- Nous conseillons une friture jusqu'à une couleur légèrement dorée au lieu d'une couleur brune.
- Conservez vos pommes de terre fraîches dans une pièce au-dessus de 8°C
- Avant la cuisson, faites tremper les pommes de terre pendant 20 minutes pour réduire la quantité d'amidon.

Pommes de terre et frites						
Frites surgelées fines	1000 g		35 min	180°C		Secouer 2 fois lors de la cuisson
Frites maison (8 x 8 mm)	1000 g		35 min	180°C		Ajouter une 1 c. à soupe d'huile + secouer 2 fois
Quartiers de pommes de terre surgelées	1000 g		35 min	180°C		Ajouter une 1 c. à soupe d'huile + secouer 2 fois

Viandes et volailles						
Escalopes de poulet	500 - 900 g		20 - 25 min	180°C		Retourner à mi-cuisson
Pilons de poulet	1500 g		25 min	200°C		
Bacon / Bacon de boeuf	8 tranches		8 min	180°C		Retourner à mi-cuisson
Saucisses	10 pièces		25 min	200°C		
Poisson						
Pavé de saumon	6 pièces (150g/pièce)		8 min	200°C		
Crevettes	12 pièces		7 min	140°C		
Snacks						
Nuggets surgelés	700 g		15 min	200°C		
Ailes de poulet surgelées	800 g		16 min	200°C		
Bâtonnets de fromages surgelés	750 g		16 min	200°C		
Pizza surgelée		FROZEN PIZZA	10 min	200°C		
Pizza fraîche	diamètre 26 cm	FRESH PIZZA	6 min	220°C		
Pizza maison		FRESH PIZZA	10 min	200°C		
Légumes						
Nems	18 pièces (900 g)		10 min	200°C		
Chou-fleur (fleurcettes)	800 g		20 min	180°C		
Courgettes	600 g		10 min	200°C		
Pâtisserie						
Cookies	9 pièces		9 - 11 min	180°C		
Déshydratation						
Pomme en rondelles	1-2 pièces		4 h	70°C		

*Remuez à mi-cuisson

IMPORTANT: Pour éviter d'endommager votre appareil, ne jamais dépasser les quantités maximales d'ingrédients et les liquides indiqués dans le mode d'emploi et dans les recettes. Lorsque vous utilisez des mélanges qui gonflent pendant la cuisson (comme un gâteau, une quiche ou des muffins), le plat du four doit ne pas être rempli plus de la moitié.

CONSEILS

- Les petits ingrédients nécessitent généralement un temps de préparation légèrement plus court que les ingrédients plus volumineux.
- Remuer les petits ingrédients à mi-cuisson permet d'optimiser le résultat final et peut contribuer à une meilleure homogénéité de la cuisson des ingrédients.
- Ajoutez de l'huile aux pommes de terre fraîches pour obtenir un résultat croustillant et secouez-les pour les couvrir uniformément. Nous recommandons 14 ml d'huile.
- Après avoir ajouté l'huile, faites frire vos ingrédients dans l'appareil dans les minutes qui suivent.
- Les bouchées qui peuvent être cuites au four peuvent également être cuites dans l'appareil.
- La quantité optimale de frites pour obtenir un résultat croustillant est de 700 grammes.
- Utilisez de la pâte toute prête pour préparer des bouchées fourrées rapidement et facilement. La pâte toute prête nécessite également un temps de préparation plus court que la pâte maison.
- Placez un plat allant au four dans la cuve de l'appareil si vous souhaitez préparer un gâteau ou une quiche ou si vous voulez cuire des ingrédients fragiles ou fourrés. Vous pouvez également utiliser un plat en silicone, en acier inoxydable, en aluminium ou en terre cuite.
- Vous pouvez également utiliser l'appareil pour réchauffer les ingrédients. Pour réchauffer les ingrédients, réglez la température à 160°C pour au plus 10 minutes. Le temps de cuisson peut être ajusté en fonction de la quantité d'aliments afin de réchauffer complètement les aliments.

CUISSON DE FRITES MAISON

Si vous souhaitez préparer des frites maison, veuillez suivre les étapes ci-dessous.

1. Épluchez les pommes de terre et coupez-les en bâtonnets de la même épaisseur.
2. Faites tremper dans l'eau les bâtonnets de pommes de terre dans un bol pendant au moins 30 minutes, retirez-les et séchez-les avec du papier absorbant.
3. Versez 1 cuillère à soupe d'huile d'olive dans un bol, mettez-y les bâtonnets et mélangez jusqu'à ce que les bâtonnets soient recouverts d'huile.
4. Enlevez les bâtonnets du bol avec vos doigts ou un ustensile de cuisine de sorte que le surplus d'huile reste dans le bol. Mettez les bâtonnets dans la cuve.

Remarque : Ne penchez pas le bol pour mettre tous les bâtonnets dans la cuve en une seule fois, afin d'éviter que le surplus d'huile reste au fond du bol.

5. Faites cuire les bâtonnets de pommes de terre conformément aux instructions de la section « Régler ».

NETTOYAGE

Nettoyez l'appareil après chaque utilisation.

Le revêtement de la cuve est anti-adhésif. N'utilisez pas d'ustensiles de cuisine métalliques ou des produits de nettoyage abrasifs pour les nettoyer, car cela peut endommager le revêtement anti-adhésif.

1. Retirez la fiche secteur de la prise murale et laissez l'appareil refroidir.
Remarque : Retirez la cuve pour laisser l'appareil refroidir plus rapidement.
2. Essuyez l'extérieur de l'appareil avec un chiffon humide.
3. Nettoyez la cuve à l'eau chaude, avec du détergent à vaisselle et une éponge non abrasive. Vous pouvez utiliser un liquide dégraissant pour enlever tout résidu de saleté.

Remarque : le bol est lavable au lave-vaisselle.

Conseil: Si la saleté adhère au fond de la cuve, remplissez la cuve avec de l'eau chaude et du détergent à vaisselle. Laissez tremper la cuve pendant environ 10 minutes.

4. Nettoyez l'intérieur de l'appareil avec de l'eau chaude et une éponge non abrasive.
5. Nettoyez l'élément chauffant avec une brosse nettoiyante pour retirer les résidus d'aliments.
6. N'immergez pas l'appareil dans l'eau ou tout autre liquide.

RANGEMENT

1. Débranchez l'appareil et laissez-le refroidir
2. Assurez-vous que toutes les pièces sont propres et sèches.

GARANTIE ET SERVICE APRÈS-VENTE

Si vous avez besoin d'un service après-vente ou d'informations ou en cas de problème, veuillez consulter le site Web de la marque (voir page de couverture de cette notice) ou contacter le service d'assistance à la clientèle de votre pays. Vous trouverez le numéro de téléphone dans le livret de garantie mondiale. S'il n'y a pas de service clients dans votre pays, veuillez vous rendre chez votre distributeur de la marque locale.

DIAGNOSTIC D'ANOMALIE

Si vous avez des problèmes avec votre appareil, visitez le site web de la marque (voir page de couverture de cette notice) pour consulter la foire aux questions ou contactez le service d'assistance à la clientèle de votre pays.

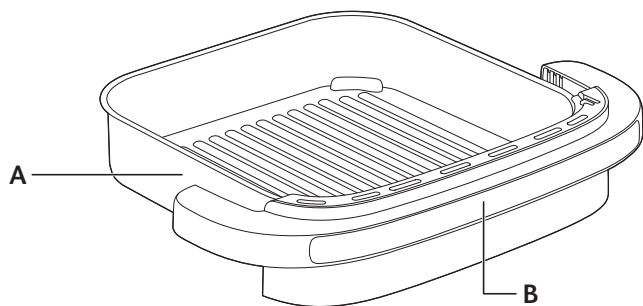
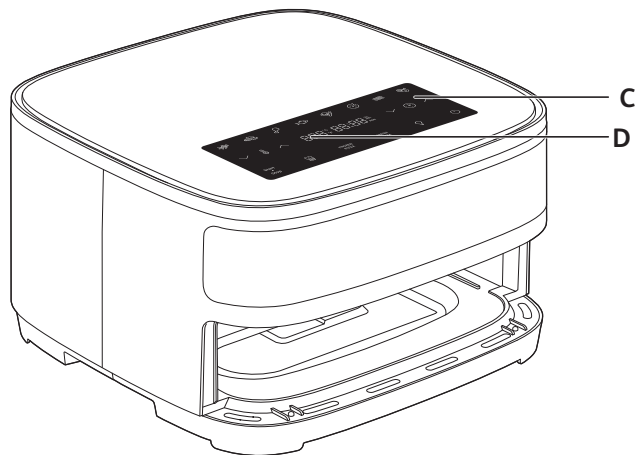

BESCHREIBUNG

- A. Schüssel
- B. Schüsselgriff
- C. Digitales Touchscreen-Feld
- D. Uhrzeit-/Temperatur-Display

AUTOMATISCHE GARMODI

- Pommes frites
- Nuggets
- Hähnchenkeulen
- Fleisch
- Gemüse
- Kekse
- Speck/Rinderspeck
- Trocknung
- Tiefkühlpizza
- Frische Pizza

VOR DEM ERSTEN GEBRAUCH

Lesen Sie die Bedienungsanleitung sorgfältig durch und bewahren Sie sie auf.

- Entfernen Sie sämtliches Verpackungsmaterial und Sie alle Etiketten oder Aufkleber von dem Gerät.
 - Waschen Sie die Schüssel, gründlich mit heißem Wasser, etwas Geschirrspülmittel und einem nicht scheuernden Schwamm ab.
- Anmerkung: Die Schüssel kann in der Spülmaschine reinigen.**
- Wischen Sie die Innen- und Außenseite des Gerätes mit einem feuchten Tuch ab. Easy Fry funktioniert durch die Erzeugung von heißer Luft. Füllen Sie die Schüssel (A) nicht mit Öl oder Frittierfett.

VORBEREITUNG FÜR DEN GEBRAUCH





- Stellen Sie das Gerät auf eine ebene, feste und hitzebeständige Arbeitsfläche geschützt vor Wasserspritzern auf.
- Füllen Sie die Schüssel nicht mit Öl oder anderen Flüssigkeiten. Stellen Sie nichts auf das Gerät. Dies würde den Luftstrom unterbrechen und das Ergebnis des Heißluftfrittierens beeinträchtigen.**

WICHTIG: Stellen Sie das Gerät nicht in eine Ecke oder unter einen Wandschrank, um ein Überhitzen zu vermeiden. Um das Gerät sollte ein Abstand von mindestens 15 cm gelassen werden, damit die Luft zirkulieren kann.



GEBRAUCH DES GERÄTS

Mit das Gerät können Sie eine große Palette von Gerichten zubereiten. Die Garzeiten für die Hauptlebensmittel werden in dem Abschnitt „Leitfaden zum Garen“ angegeben. Finden Sie online Rezepte, die Ihnen helfen, Ihr Gerät besser kennen zu lernen.



- Verbinden Sie das Netzkabel mit einer Steckdose.
- Geben Sie die Lebensmittel in die Schüssel.
Hinweis: Füllen überschreiten Sie niemals die in der Tabelle angegebene Höchstmenge (siehe Abschnitt „Garanleitung“), da andernfalls die Qualität des Gargergebnisses beeinträchtigt werden könnte.
- Setzen Sie die Schüssel wieder in das Gerät.
- Um mit der Zubereitung der Speisen zu beginnen, müssen Sie einen automatischen Modus auswählen:

- Drücken Sie die  Taste, um den Garmodus anzuzeigen.
 - Drücken Sie dann die  Taste auf dem Touchscreen, um das gewünschte Garprogramm (diese Programme werden ausführlich im Abschnitt „Garanleitung“ beschrieben) auszuwählen.
 - Um die Garzeit einzustellen, drücken Sie für die Garzeit die Taste und stellen Sie die gewünschte Zeit mit den \vee und \wedge Tasten ein. Der Timer kann zwischen 0 und 60 Minuten eingestellt werden.
 - Sie können die Temperatur  mit den \vee und \wedge Tasten auf dem digitalen Touchscreen ein. Der Temperaturregler kann von 40 bis 230°C eingestellt werden.
 - Drücken Sie die  um den Garvorgang mit der ausgewählten Temperatur und Garzeit zu starten. Der Garvorgang beginnt nun. Die ausgewählte Temperatur und verbleibende Garzeit werden abwechselnd auf dem Display angezeigt.
5. Während des Kochens ermöglicht die Innenbeleuchtung die Kontrolle des Kochvorgangs. Drücken Sie , um das Licht einzuschalten. Zum Ausschalten erneut drücken.
 6. Manche Speisen müssen nach der Hälfte der Garzeit geschüttelt werden (siehe Abschnitt „Garanleitung“). Ziehen Sie die Schüssel am Griff aus dem Gerät und schütteln Sie die Speisen. Setzen Sie die Schüssel dann wieder in das Gerät startet automatisch neu.
 7. Wenn die Garzeit abgelaufen ist, erzeugt das Gerät ein akustisches Signal und schaltet sich aus. Ziehen Sie die Schüssel aus dem Gerät und stellen Sie sie auf eine hitzebeständige Oberfläche.
 8. Prüfen Sie, ob die Speisen gar sind.
Wenn die Speisen nicht gar sind, schieben Sie einfach die Schüssel zurück in das Gerät und stellen Sie den Timer für einige zusätzliche Minuten ein.
 9. Sie die Schüssel heraus, wenn die Speisen gar sind. Nehmen Sie die Speisen mithilfe einer Zange aus der Schüssel.
Vorsicht: Heißluft sind die Schüssel, und die Speisen sehr heiß. Berühren Sie die Schüssel nicht während des Betriebs und für einige Zeit nach dem Gebrauch, da sie sehr heiß wird. Fassen Sie die Schüssel nur am Griff mit beiden Händen.

PIZZA

1. Legen Sie die Pizza in die Schüssel und schieben Sie die Schüssel zurück in das Gerät.
2. Drücken Sie , und anschließend  auf dem Display.
3. Wählen Sie die gewünschte Garzeit durch Drücken der Tasten \vee und \wedge Sie können die Temperatur mit den \wedge und \vee Tasten auf dem digitalen Touchscreen ein. (siehe Abschnitt „Garanleitung“).
4. Drücken Sie die Start-Taste, um den Garvorgang zu starten. Die Temperatur und die verbleibende Garzeit werden abwechselnd auf dem Display angezeigt.
5. Wenn die Garzeit abgelaufen ist, erzeugt das Gerät ein akustisches Signal und schaltet sich aus. Ziehen Sie die Schüssel aus dem Gerät und stellen Sie auf eine hitzebeständige Oberfläche.
6. Nehmen Sie die Schüssel heraus, wenn die Speisen gar sind. Nehmen Sie die Speisen mithilfe einer Zange aus der Schüssel.
Achtung: Nach dem Frittieren mit Heißluft sind die Schüssel, und die Speisen sehr heiß.

TROCKNUNG

1. Geben Sie die Lebensmittel in die Schüssel und Setzen Sie die Schüssel wieder in das Gerät.
2. Drücken Sie , und stellen Sie dann die Temperatur  mit den Tasten \vee und \wedge auf dem digitalen Display auf 70°C ein.
3. Stellen Sie dann die gewünschte Garzeit ein, indem Sie die Taste \vee oder \wedge drücken. Sie können eine Zeit zwischen 1 Stunde und 12 Stunden einstellen.
4. Drücken Sie  um den Trocknung zu starten. Die ausgewählte Temperatur und verbleibende Garzeit werden abwechselnd auf dem Display angezeigt.
5. Wenn die Garzeit abgelaufen ist, erzeugt das Gerät ein akustisches Signal und schaltet sich aus. Ziehen Sie die Schüssel aus dem Gerät und stellen Sie auf eine hitzebeständige Oberfläche.
6. Prüfen Sie, ob die Speisen gar sind. Wenn die Speisen nicht gar sind, schieben Sie einfach die Schüssel zurück in das Gerät und stellen Sie den Timer für einige zusätzliche Minuten ein.
7. Nehmen Sie die Schüssel heraus, wenn die Speisen gar sind. Nehmen Sie die Speisen mithilfe einer Zange aus der Schüssel.
Vorsicht: Heißluft sind die Schüssel und die Speisen sehr heiß. Berühren Sie die Schüssel nicht während des Betriebs und für einige Zeit nach dem Gebrauch, da sie sehr heiß wird. Fassen Sie die Schüssel nur am Griff mit beiden Händen.

































LEITFADEN ZUM GAREN

Die nachfolgende Tabelle hilft Ihnen, die grundlegenden Einstellungen für die Lebensmittel, die Sie zubereiten möchten, auszuwählen.

Anmerkung: Die unten aufgeführten Garzeiten sind nur eine Orientierungshilfe und können je nach Sorte und Menge der verwendeten Kartoffeln variieren. Bei anderen Lebensmitteln können die Größe, Form und Marke das Ergebnis beeinflussen. Sie müssen daher eventuell die Garzeit leicht anpassen.

Hinweis für Kartoffeln und Pommes frites

- Begrenzen Sie die Frittierertemperatur auf 180°C.
- Kontrollieren Sie das Garen. Essen Sie keine verbrannten Speisen.
- Wir empfehlen, die Kartoffeln nicht braun, sondern leicht golden zu frittieren.
- Lagern Sie Ihre frischen Kartoffeln in einem Raum mit einer Temperatur über 8 °C.
- Weichen Sie die frischen Kartoffeln vor dem Kochen 20 Minuten lang ein, um den Stärkegehalt zu reduzieren.

      						
Kartoffeln und Pommes frites						
Tiefgekühlte Pommes Frites (10 mm x 10 mm Standarddicke)	1000 g		35 min	180°C		Zweimal schütteln
Frische Pommes Frites (8 x 8 mm)	1000 g		35 min	180°C		1 EL Öl dazugeben + Zweimal schütteln
Tiefgekühlte Kartoffelspalten	1000 g		35 min	180°C		1 EL Öl dazugeben + Zweimal schütteln
Fleisch und Geflügel						
Hühnerbrustfilets (ohne Knochen)	500 - 900 g		20 - 25 min	180°C		Nach der Hälfte der Garzeit wenden
Hähnchenkeulen	1500 g (12 Stücke)		25 min	200°C		
Speck/Rinderspeck	8 Scheiben		8 min	180°C		
Wurst	10 Stücke		25 min	200°C		Nach der Hälfte der Garzeit wenden
Fisch						
Lachssteak	6 Stücke (150g/Stück)		8 min	200°C		
Garnelen	12 Stücke		7 min	140°C		
Snacks						
Hähnchennuggets tiefgekühlt	700 g		15 min	200°C		
Tiefgekühlte Hähnchenflügel	800 g		16 min	200°C		
Frozen cheese sticks	750 g		16 min	200°C		
Tiefkühlpizza	26 cm diameter	FROZEN PIZZA	10 min	200°C		
Frische Pizza		FRESH PIZZA	6 min	220°C		
Hausgemachte Pizza		FRESH PIZZA	10 min	200°C		
Gemüse						
Nems	18 Stücke (900 g)		10 min	200°C		
Blumenkohl (Oberteile)	800 g		20 min	180°C		
Zucchini	600 g		10 min	200°C		
Backen						
Keske	9 Stücke		9 - 11 min	180°C		
Auströcknung						
Äpfel in Scheiben	1-2 Stücke		4 h	70°C		

* Nach der Hälfte der Garzeit schütteln

WICHTIG: Um Beschädigungen an Ihrem Gerät zu vermeiden, überschreiten Sie niemals die Höchstmengen der in der Bedienungsanleitung und in den Rezepten angegebenen Zutaten und Flüssigkeiten. Wenn Sie Mischungen benutzen, die aufgehen (wie zum Beispiel Kuchen, Quiche oder Muffins), sollte die Auflaufform nur bis zur Hälfte gefüllt sein.

TIPPS

- Kleinere Lebensmittel benötigen gewöhnlich eine etwas kürzere Garzeit als größere Lebensmittel. Wenn Sie sich nicht sicher sind, können Sie die Schüssel jederzeit öffnen, um den Fortschritt zu überprüfen.
- Wenn Sie Lebensmittel von kleinerer Größe nach der Hälfte der Garzeit schütteln, verbessern Sie das Endergebnis. Zudem kann so verhindert werden, dass die Speisen ungleichmäßig garen.
- Damit Ihre Kartoffeln besonders knusprig werden, geben Sie vor dem Kochen eine kleine Menge Öl dazu und schütteln Sie sie, um sie gleichmäßig zu bedecken. Wir empfehlen 14 ml Öl.
- Snacks, die in einem Backofen gebacken werden können, können auch in das Gerät zubereitet werden.
- Die optimale, empfohlene Menge zur Zubereitung von Pommes frites beträgt 700 Gramm.
- Benutzen Sie Fertigmürbe- und Blätterteig, um schnell und mühelos gefüllte Snacks zuzubereiten.
- Stellen Sie eine Auflaufform in das Gerät Schüssel, wenn Sie einen Kuchen oder eine Quiche backen möchten oder wenn Sie zerbrechliche Zutaten oder gefüllte Zutaten frittieren möchten. Sie können eine Back- oder Auflaufform aus Silikon, Edelstahl, Aluminium, Terrakotta verwenden.
- Sie können die Easy Fry Fritteuse auch zum Aufwärmen von Speisen benutzen. Stellen Sie zum Aufwärmen von Speisen die Temperatur für bis zu 10 Minuten lang auf 160°C. Die Garzeit kann je nach Lebensmittelmenge angepasst werden, um die Speisen vollständig zu erwärmen.

HAUSGEMACHTE POMMES FRITES HERSTELLEN

Wenn Sie hausgemachte Pommes frites zubereiten möchten, folgen Sie diesen Schritten:

1. Wählen Sie eine Kartoffelsorte, die für die Zubereitung von Pommes frites empfohlen wird.
2. Kartoffeln schälen und in Stäbchen von ca. 1 cm Dicke schneiden.
3. Kartoffelstäbchen mindestens 30 Minuten in einer Schüssel mit kaltem Wasser einweichen, dann abtropfen lassen und mit einem sauberen, sehr saugfähigen Geschirrhandtuch abtrocknen. Dann mit einem Papiertuch abtupfen. Die Kartoffeln müssen komplett trocken sein, bevor sie frittiert werden.
4. 1 Esslöffel Öl (Pflanzen-, Sonnenblumen-, Olivenöl usw.) in eine trockene Schüssel geben, Kartoffelstäbchen darauf legen und umrühren, bis sie mit Öl bedeckt sind.
5. Pommes frites mit den Fingern oder einem Küchenutensil aus der Schüssel nehmen, sodass überschüssiges Öl in der Schüssel zurückbleibt. Pommes frites in die Schüssel geben.
Anmerkung: Kippen Sie die Behälter mit den ölbedeckten Pommes frites nicht direkt in die Schüssel, sonst läuft das überschüssige Öl in die Schüssel.
6. Frittieren Sie die Pommes frites nach den Anleitungen in dem Abschnitt Leitfaden zum Garen.

REINIGUNG

Reinigen Sie das Gerät nach jedem Gebrauch.

Die Schüssel ist mit einer Antihafbeschichtung versehen. Benutzen Sie keine Küchenutensilien aus Metall oder scheuernde Reinigungsmaterialien zur Reinigung, da diese die Antihafbeschichtung beschädigen können.

1. Ziehen Sie den Netzstecker aus der Wandsteckdose und lassen Sie das Gerät abkühlen.
Anmerkung: Entnehmen Sie die Schüssel, damit das Gerät sich schneller abkühlen kann.
2. Wischen Sie die Außenseite des Gerätes mit einem feuchten Tuch ab.
3. Waschen Sie die Schüssel mit heißem Wasser, etwas Geschirrspülmittel und einem nicht scheuernden Schwamm ab.

Sie können eine Entfettungsflüssigkeit zum Entfernen restlicher Verschmutzungen benutzen.

Anmerkung: Die Schüssel ist geschirrspülmaschinenfest.

Tipp: Falls Schmutz am Boden der Schüssel haftet, füllen Sie die Schüssel mit heißem Wasser und etwas Geschirrspülmittel. Lassen Sie die Schüssel etwa 10 Minuten lang einweichen. Dann beide Teile abspülen und abtrocknen.

4. Wischen Sie die Innenseite des Gerätes mit einem in heißem Wasser angefeuchteten Tuch sauber.
5. Reinigen Sie das Heizelement mit einer trockenen Reinigungsbürste, um Speisereste zu entfernen.
6. Tauchen Sie das Gerät nicht in Wasser oder eine andere Flüssigkeit.

AUFBEWAHRUNG

1. Ziehen Sie den Stecker des Geräts und lassen Sie das Gerät abkühlen.
2. Achten Sie darauf, dass alle Elemente sauber und trocken sind.

GARANTIE UND KUNDENDIENST

Wenn Sie den Kundendienst oder Informationen benötigen oder wenn Sie ein Problem haben, besuchen Sie unsere Website kontaktieren Sie den Kundendienst in Ihrem Land. Sie finden die Telefonnummer in dem Heft mit der weltweiten Garantie. Falls sich kein Consumer Care Centre in Ihrem Land befindet, wenden Sie sich an Ihren Händler vor Ort.

FEHLERBEHEBUNG

Falls Probleme mit Ihrem Gerät auftreten, besuchen Sie Marken-Website, wo Sie eine Liste mit häufig gestellten Fragen finden oder kontaktieren Sie den Kundendienst in Ihrem Land.

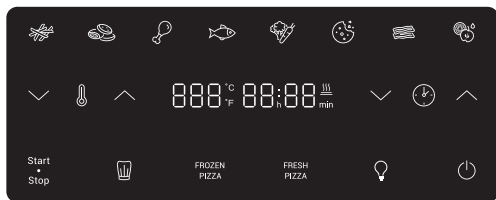
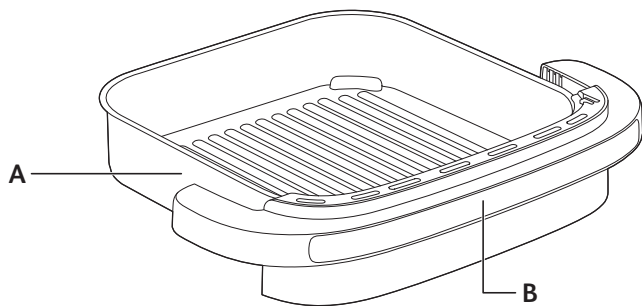
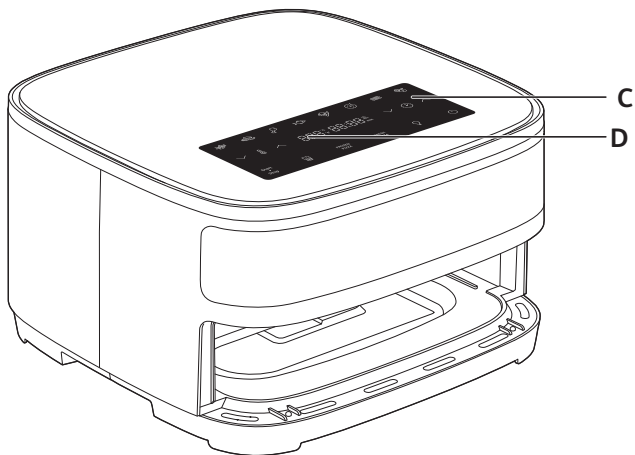

BESCHRIJVING

- A. Binnenpan
- B. Handgreep van binnenpan
- C. Digitaal aanraakscherm
- D. Tijd/temperatuurweergave

AUTOMATISCHE PROGRAMMA'S

-  Friet
-  Nuggets
-  Kip drumsticks
-  Groenten
-  Vis
-  Koekjes
-  Spek/rundvleesbacon
-  Drogen
-  Diepvriespizza
-  Verse pizza

VOOR INGEBRIJKNAME

Lees de gebruiksaanwijzing aandachtig door en bewaar het zorgvuldig.

1. Verwijder al het verpakkingsmateriaal und haal alle stickers en/of etiketten van het apparaat af.
2. Reinig de binnenpan grondig met warm water, een beetje afwasmiddel en een zachte spons.
Opmerking: de binnenpan is vaatwasmachinebestendig.
3. Veeg de binnen- en buitenkant van het apparaat schoon met een vochtige doek. Easy Fry werkt door het genereren van warme lucht. Vul de binnenpan (A) niet met olie of frituurvet.



VOOBEREIDING VOOR GEBRUIK









1. Plaats het apparaat op een vlak, stabiel en warmtebestendig oppervlak en uit de buurt van opspattend water.
2. **Vul de binnenpan niet met olie of een andere vloeistof.**
Plaats niets op het apparaat. Dit belemmert de luchtstroom en heeft een negatieve impact op het bakresultaat.

BELANGRIJK: Om oververhitting van het apparaat te vermijden, plaats het niet in een hoek of onder een kast. Er moet een ruimte van ten minste 15 cm rond het apparaat worden vrijgelaten om lucht te laten circuleren.







HET APPARAAT GEBRUIKEN

Met het apparaat kunt u vele verschillende ingrediënten bereiden. De baktijden voor de voornaamste ingrediënten zijn vermeld in de sectie «Instellingen». De online recepten zullen u helpen bij het ontdekken van het apparaat.





1. Steek de stekker in een stopcontact.
2. Doe de ingrediënten in de binnenpan.
Opmerking: Overschrijd nooit de maximum hoeveelheid zoals aangegeven in de tabel (zie de sectie ‘Kookgids’), dit kan een negatieve impact op het bakresultaat hebben.
3. Schuif de binnenpan opnieuw in het apparaat.
4. Om het bakproces te starten, moet u de automatische programma's selecteren.
 - Druk op de  knop om de programma's weer te geven.
 - Druk vervolgens op de  knop op het scherm om het gewenste programma te selecteren (deze programma's worden in detail beschreven in de sectie “Kookgids”).



- De temperatuur pas  in met de  en  knop op het digitaal scherm. De thermostaat kan worden ingesteld tussen 40 en 230°C.
 - U kunt de kooktijd aanpassen door op te  drukken en aan te passen met met de  en  knop. De timer kan worden ingesteld tussen 0 en 60 minuten.
 - Druk op de  om het bakproces met de gekozen temperatuur en tijd te starten.
 - Het bakproces start. De gekozen temperatuur en de resterende baktijd worden afwisselend op het scherm weergegeven.
5. Tijdens het koken maakt het binnenlicht het mogelijk om het kookproces te controleren. Druk op  om op te lichten. Druk nogmaals om uit te schakelen.
 6. Voor bepaalde ingrediënten is het nodig om ze op de helft van de baktijd te schudden (zie de sectie “Kookgids”). Om de ingrediënten te schudden, trek de binnenpan via de handgreep uit het apparaat en schud de binnenpan. Schuif de binnenpan vervolgens opnieuw in de Easy Fry, het apparaat start automatisch opnieuw.
 7. Als de baktijd is verstreken, hoort u een geluidssignaal en wordt het apparaat uitgeschakeld. Trek de binnenpan uit het apparaat en plaats het op een warmtebestendig oppervlak.
 8. Controleer of de ingrediënten gaar zijn.
Als de ingrediënten nog niet gaar zijn, schuif de binnenpan opnieuw in het apparaat en stel de timer nog enkele minuten in.
 9. Eenmaal de ingrediënten gaar zijn, haal de binnenpan uit het apparaat. Gebruik een tang om de ingrediënten uit de binnenpan te halen.
Opgelet: De binnenpan, en de ingrediënten zijn na het frituren zeer warm.
Raak de binnenpan tijdens en kort na gebruik niet aan, deze wordt zeer warm. Houd de binnenpan alleen bij de handgreep vast.
 10. Na het bereiden van ingrediënten, kan het apparaat onmiddellijk opnieuw gebruikt worden.

PIZZA

1. Leg de pizza in de kom en schuif de kom terug in het apparaat.
2. Druk op  en vervolgens op  of .
3. Stel vervolgens de gewenste tijd in met de  en  knop. Stel de temperatuur in met de  en  knop op het digitaal scherm.
4. Druk op de startknop om te starten met bakken. De temperatuur en de resterende bereidingstijd worden op het scherm weergegeven.
5. Als de baktijd is verstreken, hoort u een geluidssignaal en wordt het apparaat uitgeschakeld. Trek de binnenpan uit het apparaat en plaats het op een warmtebestendig oppervlak.
6. Eenmaal de ingrediënten nog niet gaar zijn, schuif de binnenpan opnieuw in het apparaat en stel de timer nog enkele minuten in.
7. Eenmaal de ingrediënten gaar zijn, haal de binnenpan uit het apparaat.
Let op: De kom, en het voedsel zijn na het frituren zeer heet.
Houd de kom alleen met beide handen vast aan het handvat.

DROGEN

1. Doe de ingrediënten in de binnenpan en schuif de kom terug in het apparaat.
2. Druk op , en stel de temperatuur  in op 70°C door op de knop  en  te drukken via het digitale scherm.

3. Stel vervolgens de gewenste bereidingstijd in door op  of  te drukken. U kunt de timer instellen op een tijd van 1 tot 12 uur.
4. Druk op  om het uitdrogingsproces te starten. De gezoken temperatuur en de resterende baktijd worden afwisselend op het scherm weergegeven.
5. Als de baktijd is verstreken, hoort u een geluidssignaal en wordt het apparaat uitgeschakeld. Trek de binnenpan uit het apparaat en plaats het op een warmtebestendig oppervlak.
6. Controleer of de ingrediënten gaar zijn. Als de ingrediënten nog niet gaar zijn, schuif de binnenpan opnieuw in het apparaat en stel de timer nog enkele minuten in.
7. Eenmaal de ingrediënten gaar zijn, haal de binnenpan uit het apparaat.
Let op: De kom en het voedsel zijn na het frituren zeer heet.
Houd de kom alleen met beide handen vast aan het handvat.

































INSTELLINGEN

Onderstaande tabel zal u helpen met het kiezen van de juiste instellingen voor de ingrediënten die u wilt bereiden.

Opmerking: de onderstaande bakinstellingen zijn louter indicatief. Deze kunnen afwijken naargelang de herkomst, grootte, merk en vorm van uw ingrediënten.

Opmerking voor aardappelen en frietjes

- Beperk de frituurtemperatuur tot 180°C.
- Controleer het koken. Eet geen aangebrand voedsel.
- We raden aan om te frituren tot een licht gouden kleur in plaats van een bruine kleur.
- Bewaar je verse aardappelen in een ruimte boven de 8°C.
- Week de verse aardappelen voor het koken 20 minuten om de hoeveelheid zetmeel te verminderen.

						
Aardappelen en friet						
Bevroren dunne friet (10 mm x 10 mm)	1000 g		35 min	180°C		Tweemaal schudden
Zelfgemaakte friet (8 x 8 mm)	1000 g		35 min	180°C		Voeg een 1 eet-lepel olie toe + tweemaal schudden
Bevroren aardappelpartjes	1000 g		35 min	180°C		Voeg een 1 eet-lepel olie toe + tweemaal schudden
Viees en gevogelte						
Kipfilet (zonder bot)	500 - 900 g		20 - 25 min	180°C		Halverwege het koken omdraaien
Kippenboutjes	1500 g (12 stuks)		25 min	200°C		
Spek/rundvleesbacon	8 plakjes		8 min	180°C		
Worst	10 stuks		25 min	200°C		Halverwege het koken omdraaien
Vis						
Zalmfilet	6 stuks (150g/stuk)		8 min	200°C		
Garnaal	12 stuks		7 min	140°C		
Snacks						
Diepgevroren kipnuggets	700 g		15 min	200°C		
Diepgevroren kippenvleugels	800 g		16 min	200°C		
Bevroren kaasengels	750 g		16 min	200°C		
Bevroren pizza	26cm diameter	FROZEN PIZZA	10 min	200°C		
Verse pizza		FRESH PIZZA	6 min	220°C		
Zelfgemaakte pizza		FRESH PIZZA	10 min	200°C		
Groenten						
Nems	18 stuks (900 g)		10 min	200°C		
Bloemkool (topjes)	800 g		20 min	180°C		
Courgette	600 g		10 min	200°C		
Bakken						
Koekjes	9 stuks		9 -11 min	180°C		
Dehydration						
Sliced apples	1-2 stuks		4 h	70°C		

* Schud halverwege het bakproces.

BELANGRIJK: Om schade aan uw apparaat te vermijden, overschrijd nooit de maximum hoeveelheden aan ingrediënten en vloeistoffen die in de gebruiksaanwijzing en recepten zijn vermeld.

***Plaats een cakevorm/ovenschaal in de kom (ovenschaal van siliconen, roestvrij staal, aluminium, terracotta).

Als u een rijzend mengsel gebruikt (zoals een cake, quiche of muffins), vul de ovenschaal niet meer dan de helft.

TIPS

- Kleinere ingrediënten hebben over het algemeen een kortere baktijd nodig dan grotere ingrediënten.
- Als u het niet zeker weet, kunt u de frituurmand op elk moment tijdens de bereiding openen om de voortgang te controleren.
- Voor extra krokante aardappelen voegt u vóór de bereiding een kleine hoeveelheid olie toe. Schud de aardappelen om de olie goed te verdelen. We raden 14 ml olie aan.
- Het schudden van kleinere ingrediënten aan de helft van de baktijd verbetert het eindresultaat en kan helpen bij het vermijden van een ongelijkmatig bakproces.
- Snacks die in de oven bereid kunnen worden, kunnen tevens in de Easy Fry worden gebakken.
- De optimale aanbevolen hoeveelheid te frituren friet is 700 gram.
- Gebruik kant-en-klare bladerdeeg of zanddeeg om op een snelle en eenvoudige manier gevulde snacks te bereiden.
- Plaats een ovenschaal in de Easy Fry als u een cake of quiche wilt bakken of als u delicate of gevulde levensmiddelen wilt frituren. Gebruik hiervoor een ovenschaal van siliconen, roestvrij staal, aluminium of terracotta.
- U kunt de Easy Fry tevens gebruiken voor het opwarmen van ingrediënten. Om de ingrediënten op te warmen, stel de temperatuur gedurende 10 minuten op 160°C in.
- De bereidingstijd kan worden aangepast aan de hoeveelheid voedsel om het eten volledig op te warmen.

ZELFGEMAAKTE FRIET BEREIDEN

Als u zelfgemaakte friet wilt bereiden, volg onderstaande stappen.

1. Kies een aardappelsoort die voor het maken van friet is aanbevolen. Schil de aardappelen en snij ze in frieten van een gelijke dikte.
2. Week de friet minstens 30 minuten in een kom met koud water, voer het water af en maak de friet droog met een schone en goed absorberende theedoek. Dep ze vervolgens droog met keukenpapier. De friet moet voor het frituren goed droog zijn.
3. Giet 1 eetlepel olie in een kom, voeg de friet toe en meng totdat de friet volledig met olie is bedekt.
4. Haal de friet met uw vingers of keukengerei uit de schaal zodat de overtollige olie in de schaal achterblijft. Doe de friet in de binnenpan.
Opmerking: om te vermijden dat er olie op de bodem van de binnenpan komt te liggen, raden wij u aan om de binnenpan niet om te draaien om de friet in de mand te doen.
5. Frituur de friet zoals vermeld in de sectie "instellingen".

REINIGING

Reinig het apparaat na elk gebruik.

De binnenpan is voorzien van een anti-aanbaklaag. Gebruik geen metalen keukengerei of agressief reinigingsmiddel om schade aan de anti-aanbaklaag te vermijden.

1. Haak de stekker uit het stopcontact en laat het apparaat afkoelen. Opmerking: verwijder de binnenpan voor een snellere afkoeling.
2. Veeg de buitenkant van het apparaat schoon met een vochtige doek.
3. Maak de binnenpan in een warm sopje en met een niet-schurende spons. U kunt tevens een ontvettingsmiddel gebruiken om alle vuil te verwijderen.
Opmerking: de binnenpan is vaatwasmachinebestendig.
Tip: als er etensresten aan de pan of de bodem van de binnenpan vastkleven, vul de binnenpan met een warm sopje. Laat dit circa 10 minuten weken.
4. Maak de binnenkant van het apparaat schoon met warm water en een niet-schurende spons.
5. Dompel de behuizing van het apparaat nooit in water.
6. Maak het verwarmingselement schoon met een schoonmaakborstel om de etensresten te verwijderen.

OPSLAG

1. Haal de stekker uit het stopcontact en zorg dat het apparaat voldoende is afgekoeld.
2. Zorg dat alle onderdelen schoon en droog zijn.

GARANTIE EN KLANTENSERVICE

Als u contact wilt opnemen met onze klantenservice voor meer informatie of er treedt een probleem op, raadpleeg de website of neem contact op met de klantenservice van uw land. Het telefoonnummer bevindt zich in het wereldwijde garantieboekje. Als er geen klantenservice in uw land is, neem contact op met uw lokale winkelier.

FOUTOPSPORING

Als er een probleem met uw apparaat optreedt, ga naar website van om de sectie probleemoplossing te raadplegen of neem contact op met de klantenservice in uw land.

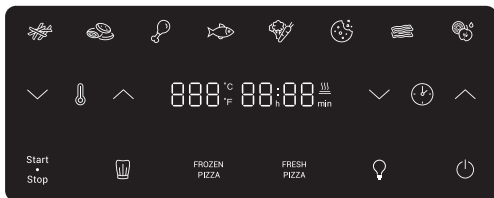
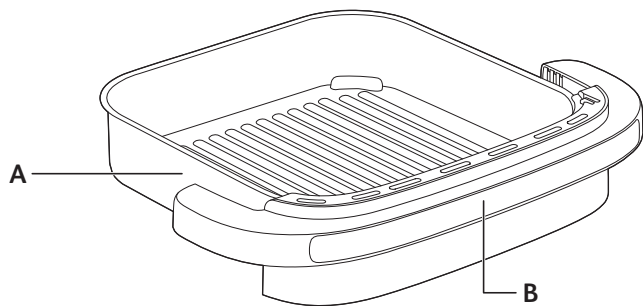
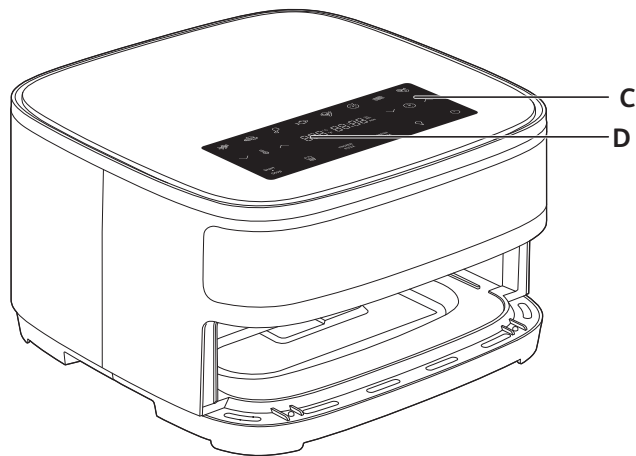

DESCRIPCIÓN

- A. Canasta
- B. Asa de la canasta
- C. Panel táctil digital
- D. Pantalla de temperatura/tiempo

MODOS AUTOMÁTICOS DE COCCIÓN

- | | |
|---------------------|-------------------------|
| Papas a la francesa | Galletas |
| Pepitas | Beicon de cerdo/ternera |
| Palillos de pollo | Deshidración |
| Pescado | PIZZA congelada |
| Verduras | PIZZA fresca |

ANTES DE USAR POR PRIMERA VEZ

Lea su manual y guárdelo cuidadosamente.

1. Retire todo el material de embalaje y las calcomanías del aparato.
2. Limpie minuciosamente la sartén con agua caliente, un poco de líquido lavavajillas y una esponja no abrasiva.

Nota : Se puede limpiar la canasta en el lavavajillas.

3. Limpie el interior y el exterior del aparato con un paño húmedo. El dispositivo funciona con aire caliente. No llene la canasta con aceite o grasa para freír.

PREPARACIÓN PARA EL USO









1. Ubique el aparato en una superficie nivelada, horizontal y estable. No coloque el aparato en superficies que no sean resistentes al calor.
2. **No llene la canasta con aceite ni otro líquido.**
No coloque nada encima del aparato. Esto interrumpe el flujo de aire y afecta el resultado de freído con aire caliente.

IMPORTANTE: Para evitar que el aparato se sobrecaliente, no lo coloques en una esquina ni bajo una alacena de pared. Es necesario dejar un hueco de al menos 15 cm en torno al aparato para que circule el aire.









USO DEL APARATO

El aparato puede cocinar una amplia gama de recetas. Los tiempos de cocción de los alimentos principales se encuentran en la sección "Guía de cocción". Las recetas en línea le ayudarán a conocer el aparato.









1. Enchufe el cable de alimentación en el tomacorriente.
2. Coloque los ingredientes en la canasta.
Nota: Nunca llene la canasta más allá de la indicación MÁX. ni exceda la cantidad indicada en el cuadro (vea la sección «Ajustes»), ya que esto podría afectar la calidad del resultado final.
3. Vuelva a deslizar la canasta dentro del aparato.
4. Para comenzar a cocinar, se debe seleccionar la configuración del modo de cocción automático.
 - Presione el botón para ver el modo de cocción en pantalla.
 - Después, presione el botón en pantalla para seleccionar el modo de cocción deseado (estos modos se describen en detalle en la sección "Guía de cocción").

- Se puede cambiar el tiempo de cocción deseado presionando el botón  y ajustando el tiempo con los botones  y . El temporizador se puede configurar entre 0 y 60 minutos.
 - Si se necesita, ajuste la temperatura  con los botones  y  en la pantalla digital. El termostato varía de 40 - 230°C.
 - Presione el botón  para comenzar a cocinar con las configuraciones de temperatura y tiempo seleccionadas.
 - La cocción comenzará. La temperatura seleccionada y el tiempo restante de cocción se alternarán en la pantalla.
5. Durante la cocción, la luz interior permite comprobar el proceso de cocción. Presione  para encender. Presione nuevamente para apagar.
 6. Algunos ingredientes requieren agitado a la mitad de su tiempo de preparación (vea la sección «Ajustes»). Para agitar los ingredientes, retire la sartén del aparato por la asa y agítela. Después, deslice el recipiente hacia dentro del artefacto y presione el botón de inicio de nuevo para reanudar la cocción, el aparato se reinicia automáticamente.
 7. Cuando escuche la campanilla del temporizador, el tiempo de preparación establecido habrá finalizado.
Retire la canasta del aparato y colóquela sobre una superficie resistente al calor.
 8. Verifique que los ingredientes estén preparados.
Si los ingredientes no están listos todavía, simplemente deslice la canasta nuevamente dentro del aparato y configure el temporizador con unos minutos adicionales.
 9. Vacíe la canasta dentro de un tazón o una bandeja.
Para retirar los ingredientes, use un par de pinzas para levantar los ingredientes y retirarlos de la canasta.
Precaución: Después de freír con aire caliente, la canasta y los ingredientes están calientes. No toque la canasta durante el uso y cierto tiempo después de usarla ya que se calienta mucho. Solo sostenga la canasta por el asa con ambas manos.
 10. Cuando una tanda de alimentos esté lista, el artefacto está inmediatamente preparado para cocinar la siguiente tanda.

PIZZA

1. Coloque la pizza en la sartén y deslicela dentro del aparato.
2. Presione el botón , luego presione  o .
3. Ajuste el tiempo de cocción presionando los botones  y .
Ajuste la temperatura  con  y  en la pantalla digital.
4. Presione el botón de inicio  para comenzar a cocinar. La temperatura y el tiempo restante de cocción se alternan en la pantalla.
5. Cuando escuche la campanilla del temporizador, el tiempo de cocción establecido habrá finalizado.
Retire la canasta del aparato y colóquela sobre una superficie resistente al calor.
6. Verifique que los ingredientes estén preparados. Si los ingredientes no están listos todavía, simplemente deslice la canasta nuevamente dentro del aparato y configure el temporizador con unos minutos adicionales.
7. Cuando los ingredientes están listos, vacíe la canasta dentro de un tazón o una bandeja.
Para retirar los ingredientes, use un par de pinzas para levantar los ingredientes y retirarlos de la canasta.
Precaución: Después de freír con aire caliente, la canasta y los ingredientes están calientes.

DESHIDRACIÓN

1. Coloque los ingredientes en la canasta. Deslice la sartén hasta el interior del artefacto.
2. Presione el botón , luego ajuste la temperatura  con el botón  y  hasta 70°C.
3. Después, configure el tiempo deseado presionando el botón  y ajustando el tiempo con los botones  y . El temporizador se puede configurar entre 1 y 12 horas.
4. Presione el botón de inicio  para comenzar la deshidratación. La temperatura seleccionada y el tiempo restante se alternarán en la pantalla.
5. Cuando escuche la campanilla del temporizador, el tiempo de preparación establecido habrá finalizado. Retire la canasta del aparato y colóquela sobre una superficie resistente al calor.
6. Verifique que los ingredientes estén preparados. Si los ingredientes no están listos todavía, simplemente deslice la canasta nuevamente dentro del aparato y configure el temporizador con unos minutos adicionales.
7. Cuando los ingredientes están listos, vacíe la sartén. Use un par de pinzas para levantar los ingredientes y retirarlos de la canasta.

Precaución: No toque la sartén durante el uso y después ya que se calienta mucho. Solo sostenga la canasta por la asa con ambas manos.

AJUSTES

Este cuadro a continuación le ayuda a seleccionar los ajustes básicos para los ingredientes que desea preparar.

Nota: Recuerde que estos ajustes son indicaciones. Dado que los ingredientes difieren en su origen, tamaño, forma y marca, no podemos garantizar el mejor ajuste para sus ingredientes.

Nota para patatas y patatas fritas

- Limitar la temperatura de fritura a 180°C.
- Controle la cocción. No consuma alimentos quemados.
- Aconsejamos freír hasta obtener un color ligeramente dorado en lugar de marrón.
- Conserve las patatas frescas en una habitación a más de 8°C.
- Antes de cocinarlas, deje las patatas frescas en remojo durante 20 minutos para reducir la cantidad de almidón.

2. Limpie el exterior del aparato con un paño húmedo.
3. Limpie la canasta con agua caliente, un poco de líquido lavavajillas y una esponja no abrasiva. Puede usar un líquido desengrasante para retirar la suciedad que reste.

Nota : Se puede limpiar la canasta en el lavavajillas.

Consejo: Si hay suciedad pegada en la parte inferior de la sartén, llene la sartén con agua caliente y algo de líquido lavavajillas. Déjela en remojo por aproximadamente 10 minutos.

4. Limpie el interior del aparato con agua caliente y una esponja no abrasiva.
5. Limpie el elemento de calentamiento con un cepillo de limpieza para retirar los residuos de comida que haya.

ALMACENAMIENTO

1. Desenchufe el aparato y déjelo enfriar.
2. Asegúrese de que todas las partes estén limpias y secas.

MEDIO AMBIENTE

No arroje el aparato con la basura normal del hogar cuando termine su vida útil, entréguelo en un punto de recolección oficial para su reciclado. Al hacer esto ayudará a conservar el medio ambiente.

GARANTÍA Y SERVICIO

Si necesita servicio o información o si tiene un problema, visite la página web de la marca (ver la portada de este manual) o comuníquese con el Centro de atención al consumidor de la marca en su país. Encontrará el número de teléfono en el folleto de garantía mundial. Si no hay Centro de atención al cliente en su país, vaya al distribuidor local de la marca.

DETECCIÓN DE PROBLEMAS

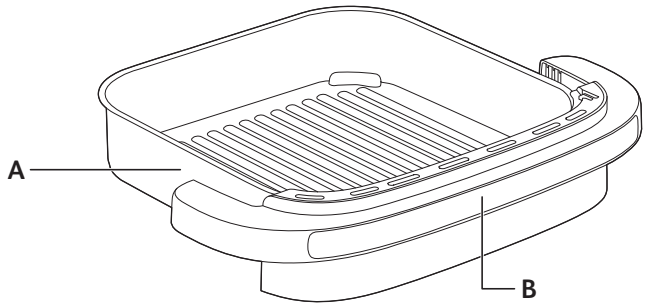
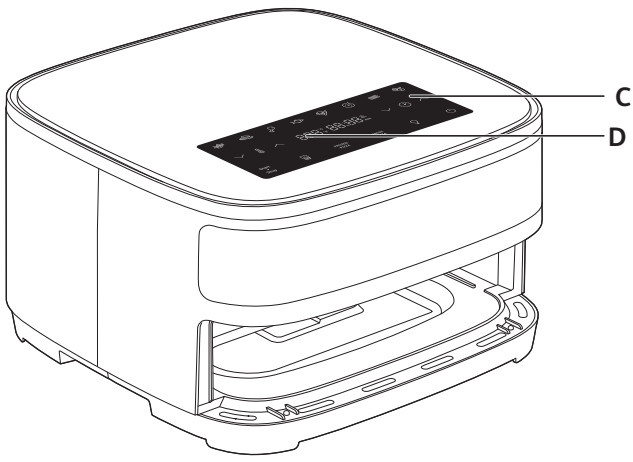

Si tiene problemas con el aparato, visite la página web de la marca (ver la portada de este manual). Para ver una lista de preguntas frecuentes o comuníquese con el Centro de atención al cliente.



DESCRIÇÃO

- A. Cuba
- B. Alça da cuba
- C. Painel digital touch screen
- D. Visor de tempo/temperatura

MODOS DE COZIMENTO AUTOMÁTICO

- | | |
|--|---|
|  Fritas |  Biscoitos |
|  Nuggets frango |  Bacon/bacon de vaca |
|  Coxinhas de frango |  Desidratação |
|  Peixe |  FROZEN PIZZA
Pizza congelada |
|  Legumes |  FRESH PIZZA
Pizza fresca |

ANTES DO PRIMEIRO USO

Em primeiro lugar, leia as instruções de segurança e o manual e guarde-os num local seguro.

1. Remova todos os objetos da embalagem e qualquer adesivo do equipamento.
2. Não remova as almofadas de silicone da grade.
3. Limpe bem a cuba e a grade removível com água quente, um pouco de detergente líquido e uma esponja não abrasiva.
Observação: Você também pode limpar a cuba na máquina de lavar louça.
4. Limpe o interior e exterior do equipamento com um pano molhado. O aparelho funciona produzindo ar quente. Não preencha cuba com óleo ou gordura para fritura.

PREPARANDO PARA USO









1. Coloque o equipamento em uma superfície estável, horizontal e nivelada. Não coloque o aparelho sobre uma superfície não resistente ao calor.
2. **Não preencha cuba com óleo ou qualquer outro líquido. Não coloque nada em cima do equipamento. Isso interrompe o fluxo de ar e afeta o resultado da fritura em ar quente.**

IMPORTANTE: para evitar o sobreaquecimento do aparelho, não o coloque num canto ou encostado a um armário de parede. Deve deixar uma distância de, pelo menos, 15 cm à volta do aparelho para permitir a circulação de ar.









USANDO O EQUIPAMENTO

O equipamento pode preparar um amplo leque de receitas. O tempo de preparo para os principais alimentos é indicado na seção 'Guia de cozinha'. As receitas online ajudam-no a conhecer o aparelho.







1. Insira o plugue em uma tomada de acordo com a voltagem do produto.
2. Coloque os ingredientes na cuba.
Observação: Nunca preencha a cuba além da indicação MÁX ou exceda a quantidade indicada na tabela (consulte a seção 'Configurações'), pois isso pode afetar a qualidade do resultado final.
3. Coloque a cuba de volta ao aparelho.

4. Para começar a cozinhar, você deve selecionar um modo de cozimento automático:
 - Pressione o botão  para exibir o modo de cozimento.
 - Pressione em seguida o botão  na tela para escolher o modo de cozimento desejado (esses modos são descritos em detalhe na seção "Guia de cozimento").
 - Você pode alterar o tempo de cozimento, pressionando o botão  e ajustando o tempo com os botões  e . O timer pode ser definido para de 0 a 60 minutos.
 - Ajuste a temperatura  com os botões  e  na tela digital. O termostato varia de 40 a 230°C.
 - Pressione o botão Start para iniciar o cozimento com os dados escolhidos de temperatura e tempo. Inicia-se o cozimento. A temperatura escolhida e o tempo de cozimento restante vão alternar-se na tela do visor.
5. Durante a cozedura, a luz inferior permite verificar o processo de cozedura. Pressione  para acender. Pressione novamente para desligar.
6. Alguns alimentos precisam ser agitados na metade do tempo de cozimento (ver seção "Guia de Cozimento"). Para mexer os alimentos, puxe o cesto para fora do aparelho pela pega e agite-o. Em seguida, deslize o copo de volta no aparelho. O aparelho reinicia automaticamente.
7. Quando ouvir o apito do timer, o tempo de preparação definido se esgotou. Retire a cuba do aparelho e coloque-a sobre uma superfície resistente ao calor.
8. Verifique se a comida está pronta.
Se a comida ainda não estiver pronta, basta colocar a cuba de volta no aparelho e ajustar o timer para alguns minutos extras.
9. Quando a comida estiver cozida, retire a cuba. Para remover o alimento, use um par de pinças para retirá-la da cuba.
Cuidado: Depois de fritar em ar quente, a cuba, e a comida ficam muito quentes. Não toque na panela durante e algum tempo após o uso, pois ela fica muito quente. Só segure a panela pela alça com as duas mãos.
10. Assim que o alimento estiver pronto, o aparelho fica pronto de imediato para preparar outra receita.

PIZZA

1. Colocar a piza na taça e voltar a colocar a taça no aparelho.
2. Prima  e, em seguida, prima  ou .
3. Ajuste o tempo de cozimento premindo os botões  e . Ajuste a temperatura com os botões  e  na tela digital.
4. Prima o botão de iniciar para iniciar a cozedura . A temperatura e o tempo de cozedura restante serão apresentados alternadamente no ecrã.
5. Quando ouvir o som do temporizador, a cozedura terá terminado. Retire o cesto do aparelho e coloque-o numa superfície resistente ao calor.
6. Quando os alimentos estiverem cozinhados, retire o cesto.
Cuidado: Depois de fritar em ar quente, a cuba e a comida ficam muito quentes. Não toque na panela durante e algum tempo após o uso, pois ela fica muito quente. Só segure a panela pela alça com as duas mãos.

DESIDRATAÇÃO

































1. Coloque os ingredientes na cuba e deslize-a de volta para o aparelho.
 2. Pressione  e ajuste a temperatura pressionando os botões  e  para 70°C na tela digital.
 3. Em seguida, ajusta o tempo de cozimento  o botão  e . Você pode definir o tempo de 1 a 12 horas.
 4. Pressione o botão Iniciar para iniciar o processo de desidratação. A temperatura selecionada e o tempo restante de cozimento alternarão na tela.
 5. Quando ouvir o som do temporizador, o processo terminou. Retire a cesta removível do aparelho e coloque-a sobre uma superfície resistente ao calor.
 6. Verifique se a comida está pronta. Se os alimentos ainda não estiverem prontos, volte a colocá-los no aparelho e programe o temporizador para mais alguns minutos.
 7. Quando os alimentos estiverem prontos, retire a cesta. Para remover os alimentos, use um pegador para retirar os alimentos da cesta.
- Cuidado: Depois de fritar em ar quente, a cuba e a comida ficam muito quentes. Não toque na panela durante e algum tempo após o uso, pois ela fica muito quente. Só segure a panela pela alça com as duas mãos.**

GUIA DE COZIMENTO

A tabela abaixo ajuda você a selecionar as configurações básicas para preparar a comida que você deseja. **Observação: Tenha em mente que essas configurações são indicações. Como alimentos diferem em origem, tamanho, forma e marca, não podemos garantir a melhor configuração para seus alimentos.**

NOTA para as batatas e as batatas fritas

- Limitar a temperatura de fritura a 180°C.
- Controlar a cozedura. Não comer alimentos queimados.
- Aconselhamos a fritar até obter uma cor ligeiramente dourada em vez de castanha.
- Conservar as batatas frescas num local com temperatura superior a 8°C.
- Antes de cozinhar, deixe as batatas frescas de molho durante 20 minutos para reduzir a quantidade de amido.

								
Batatas e fritas								
Batata frita congelada (espessura 10 mm x 10 mm)	1000 g		35 min	180°C				2 batidos
Batata frita in natura (8 x 8 mm)	1000 g		35 min	180°C				Adicione 1 colher de sopa de óleo + 2 batidos
Batata rústica congelada	1000 g		35 min	180°C				Adicione 1 colher de sopa de óleo + 2 batidos
Carne e aves								
Filés de peito de frango (sem osso)	500 - 900 g		20 - 25 min	180°C				Virar a meio da cozedura
Coxinhas de frango	1500 g (12 pedaços)		25 min	200°C				
Bacon/bacon de vaca	8 fatias		8 min	180°C				
Chouriço	10 pedaços		25 min	200°C				Virar a meio da cozedura
Peixe e frutos do mar								
Filé de salmão	6 peças (150g/peças)		8 min	200°C				
Camarões médios	12 pedaços		7 min	140°C				
Snacks								
Nuggets de frango congelados	700 g		15 min	200°C				
Asas de frango congeladas	800 g		16 min	200°C				
Palitos de queijo congelados	750 g		16 min	200°C				
Pizza congelada	26cm diâmetro	FROZEN PIZZA	10 min	200°C				
Pizza fresca		FRESH PIZZA	6 min	220°C				
Pizza caseira		FRESH PIZZA	10 min	200°C				
Vegetais								
Nêsperas	18 peças (900 g)		10 min	200°C				
Couve-flor (topos)	800 g		20 min	180°C				
Abobrinhas	600 g		10 min	200°C				
Cozimento								
Biscoitos	9 pedaços		9-11 min	180°C				
Desidratação								
Maçãs em fatias	1-2 pedaços		4 h	70°C				

*Agite na metade do cozimento.

IMPORTANTE: para evitar danificar o aparelho, nunca exceda as quantidades máximas de ingredientes e líquidos indicadas no manual de instruções e nas receitas. Quando utiliza misturas com fermento (como bolos, quiche ou queques), não deve encher o recipiente mais do que metade.

DICAS

- Uma quantidade maior de alimento requer um tempo de preparação um pouco maior, uma quantidade menor de alimento requer um tempo de preparação um pouco menor.
- Se não tiver a certeza, pode abrir o cesto a qualquer momento da cozedura para verificar o progresso.
- Para tornar as suas batatas ainda mais estaladiças, tente adicionar uma pequena quantidade de óleo antes de cozinhar e agite para cobrir uniformemente. Recomendamos 14 ml de óleo.
- Agitar alimentos menores no meio da preparação otimiza o resultado final e pode ajudar a evitar ingredientes fritos de forma desigual.
- Não prepare ingredientes muito gordurosos, como salsichas, na aparelho.
- Os alimentos que podem ser preparados em um forno também podem ser preparados na aparelho.
- A quantidade ideal para a preparação de batatas fritas crocantes é de 700 gramas.
- Use uma massa pré-fabricada para preparar lanches com recheio de forma rápida e fácil. A massa pré-fabricada também requer um tempo de preparação mais curto do que a massa caseira.
- Coloque em uma forma que pode ser levada ao forno na cuba se quiser assar um bolo ou quiche, ou caso queira fritar ingredientes frágeis ou ingredientes com recheio.
- Você também pode usar a aparelho para reaquecer os ingredientes. Para reaquecer os ingredientes, ajuste a temperatura para 160 ° C por até 10 minutos.
- O tempo de cozedura pode ser ajustado dependendo da quantidade para reaquecer completamente os alimentos.

FAZENDO BATATA FRITA IN NATURA

Se deseja fazer batatas fritas in natura, siga as etapas abaixo.

1. Descasque as batatas e corte-as em palitos.
2. Mergulhe os palitos de batata em uma tigela com água por pelo menos 30 minutos, tire-os e seque-os com papel toalha.
3. Despeje 1 colher de sopa de azeite em uma tigela, coloque os palitos na parte superior e misture até os palitos serem revestidos com óleo.
4. Remova os palitos da tigela com os dedos ou um utensílio de cozinha para que o excesso de óleo permaneça na tigela. Coloque os palitos na cuba.
Observação: Não incline a tigela para colocar todos os palitos na equipamento cuba de uma só vez, para evitar que o excesso de óleo acabe na parte inferior da panela.
5. Frite os palitos de batata de acordo com as instruções na seção 'Configurações'.

LIMPEZA

Limpe o equipamento após cada uso.

A cuba possuem um revestimento antiaderente. Não use utensílios de cozinha metálicos ou materiais de limpeza abrasivos para limpá-los, pois isso pode danificar o revestimento antiaderente.

1. Remova o plugue da tomada e deixe o aparelho esfriar. Observação: Retire a cuba para deixar a aparelho esfriar mais rapidamente.
2. Limpe o exterior do equipamento com um pano úmido.

3. Limpe a cuba com água quente, um pouco de detergente líquido e uma esponja não abrasiva.

Você pode usar um líquido tira gordura para remover a sujeira restante.

Observação: A cuba são laváveis na máquina de lavar louça.

Dica: Se a sujeira estiver grudada no fundo da cuba, encha-as com água quente e um pouco de detergente. Deixe a cuba de molho por aproximadamente 10 minutos. Em seguida, enxague e seque.

4. Limpe o interior do equipamento com água quente e uma esponja não abrasiva.
5. Limpe o elemento de aquecimento com uma escova de limpeza para remover quaisquer resíduos de alimentos.
6. Não mergulhe o aparelho em água ou qualquer outro líquido.

ARMAZENAMENTO

1. Desconecte o aparelho e deixe esfriar.
2. Verifique se todas as peças estão limpas e secas.

AMBIENTE

Não jogue o equipamento fora com lixo doméstico normal no final de sua vida útil, descarte-o em um ponto de coleta oficial para reciclagem. Ao fazer isso, você ajuda a preservar o meio ambiente

GARANTIA E SERVIÇO

Se precisar de serviços ou informações ou caso tenha um problema, visite o site da marca (veja a capa destas instruções de uso) ou entre em contato com o Centro de atendimento ao cliente da marca em seu país. Você encontra seu número de telefone no folheto de garantia mundial.

RESOLUÇÃO DE PROBLEMAS

Se encontrar problemas no aparelho, visite o site da marca para obter uma lista de perguntas frequentes ou entre em contato com o Centro de atendimento ao cliente em seu país

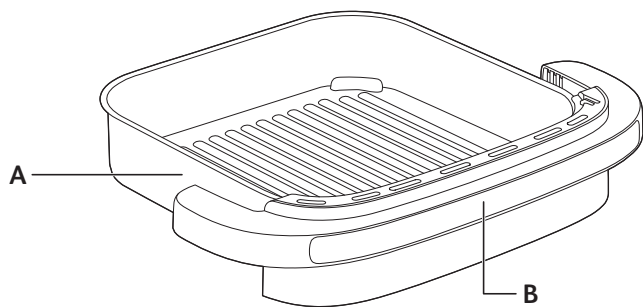
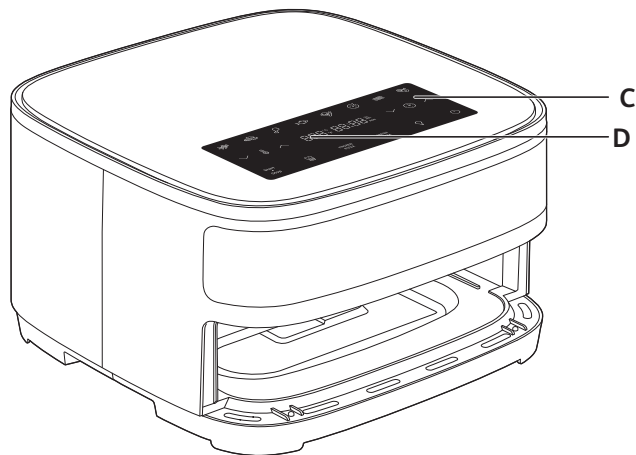

DESCRIZIONE

A. Cestello

B. Maniglia del cestello

C. Pannello touch screen digitale

D. Display tempo/temperatura

MODALITÀ DI COTTURA AUTOMATICA

Patatine fritte

Crocchette di pollo

Bastoncini di pollo

Pesce

Verdure

Biscotti

Pancetta/Pancetta di manzo

Disidratazione

Pizza surgelata

Pizza fresca

PRIMA DEL PRIMO UTILIZZO

Leggere prima le istruzioni e il manuale di sicurezza e conservarli in un luogo sicuro.

1. Rimuovere tutto il materiale di imballaggio e eventuali adesivi dall'apparecchio.
2. Pulire accuratamente il cestello con acqua calda, un po' di detersivo per piatti e una spugna non abrasiva.

Nota: Il cestello è lavabile in lavastoviglie.

3. Pulire la parte interna ed esterna dell'apparecchio con un panno umido. L'apparecchio funziona producendo aria calda. Non riempire il cassetto con olio o grasso per frittura.

PREPARAZIONE PRIMA DELL'USO

1. Posizionare l'apparecchio su una superficie di lavoro piana, stabile e resistente al calore, lontana da spruzzi d'acqua.
2. **Non riempire il cestello con olio o altri liquidi.**
Non appoggiare nulla sull'apparecchio perché ciò potrebbe ostacolare il flusso d'aria e compromettere il risultato della frittura ad aria calda.

IMPORTANTE: per evitare che l'apparecchio si surriscaldi, non posizionarlo in un angolo o sotto un pensile. È necessario lasciare un spazio di almeno 15 cm intorno all'apparecchio per permettere all'aria di circolare.

USO DELL'APPARECCHIO

L'apparecchio è in grado di cuocere un'ampia varietà di ricette. I tempi di cottura degli alimenti principali sono indicati nella sezione «Guida alla cottura». Le ricette online ti aiutano a conoscere l'apparecchio.

1. Collegare il cavo di alimentazione a una presa elettrica.
2. Posizionare il alimento nel cestello.

Nota: non superare mai la quantità massima indicata nella tabella (vedere la sezione «Guida alla cottura»), poiché ciò potrebbe compromettere la qualità del risultato finale.

3. Reinsерire il cestello nell'apparecchio.
4. Per iniziare la cottura, è necessario selezionare la modalità di cottura predefinita.
 - Premere il tasto per visualizzare la modalità di cottura.
 - Premere il tasto sul display per selezionare la modalità di cottura desiderata (le modalità sono descritte in dettaglio nella sezione «Guida alla cottura»).

- È possibile modificare il tempo di cottura premendo e regolarlo con i tasti e . È possibile impostare il timer tra 0 e 60 minuti.
 - Regolare la temperatura con i pulsanti con i pulsanti e sul display digitale. Il termostato varia da 40 a 230 °C.
 - Premere il tasto per iniziare la cottura con le impostazioni selezionate di temperatura e tempo.
 - La cottura ha inizio. Sul display viene visualizzato il tempo di cottura rimanente.
5. Durante la cottura, la luce interna permette il controllo del processo di cottura. Premere per accendere. Premere di nuovo per spegnere.
 6. È necessario scuotere alcuni alimenti a metà del tempo di cottura (vedere la sezione «Guida alla cottura»). Per eseguire questa operazione, estrarre il recipiente dall'apparecchio afferrandolo per la maniglia e scuoterlo. Quindi reinserire il recipiente nell'apparecchio e la cottura si riavvierà automaticamente.
 7. Quando si sente il suono del timer, il tempo di cottura impostato è terminato. Estrarre il recipiente dall'apparecchio e poggiarlo su una superficie resistente al calore.
 8. Controllare che il cibo sia pronto.
Se non è ancora pronto, è sufficiente reinserire il recipiente e impostare il timer per qualche altro minuto.
 9. Quando l'alimento è cotto, estrarre il recipiente. Per estrarre gli alimenti dal recipiente, utilizzare un paio di pinze.
Attenzione: Dopo la cottura, la ciotola, e gli alimenti sono molto caldi. non toccare il recipiente durante l'uso e per un po' di tempo dopo l'uso, poiché diventa molto caldo. Il recipiente va tenuto esclusivamente per la maniglia con entrambe le mani.
 10. Quando un lotto di alimenti è cotto, l'apparecchio è subito pronto per preparare un altro lotto.

PIZZA

1. Posizionare il alimento nel cestello e reinserire il cestello nell'apparecchio.
2. Premere , quindi premere o .
3. Impostare quindi il tempo di cottura pulsanti e . Regolare la temperatura con i pulsanti e sul display digitale.
4. Premere il tasto di avvio per iniziare la cottura. Sul display si alterneranno la temperatura e il tempo di cottura rimanente.
Nota: la carne deve essere girata a metà cottura.
L'olio in eccesso proveniente dagli alimenti viene raccolto sul fondo del recipiente.
5. Quando si sente il suono del timer, la cottura è terminata. Estrarre il cestello dall'apparecchio e poggiarlo su una superficie resistente al calore.
6. Controllare che il cibo sia pronto. Se non è ancora pronto, è sufficiente reinserire il recipiente e impostare il timer per qualche altro minuto.
7. Quando l'alimento è cotto, estrarre il recipiente.
Attenzione: Dopo la cottura, la ciotola e gli alimenti sono molto caldi. non toccare il recipiente durante l'uso e per un po' di tempo dopo l'uso, poiché diventa molto caldo. Il recipiente va tenuto esclusivamente per la maniglia con entrambe le mani.

DISIDRATAZIONE

1. Posizionare gli alimenti nel cestello e reinserire il cestello nell'apparecchio.
2. Premere , quindi impostare la temperatura premendo i pulsanti e a 70°C sul display digitale.
3. Impostare quindi il tempo di cottura desiderato pulsanti e . È possibile impostare la durata da 1 ora a 12 ore.
4. Premere il tasto di avvio per iniziare il processo di disidratazione. Sul display si alterneranno la temperatura selezionata e il tempo di cottura rimanente.
5. Quando si sente il suono del timer, la cottura è terminata. Estrarre la ciotola dall'apparecchio e poggiarla su una superficie resistente al calore.
6. Controllare che il cibo sia pronto. Se non è ancora pronto, è sufficiente reinserire il recipiente e impostare il timer per qualche altro minuto.
7. Quando l'alimento è cotto, estrarre il recipiente. Per estrarre gli alimenti dal recipiente.
Attenzione: Dopo la cottura, la ciotola, e gli alimenti sono molto caldi. non toccare il recipiente durante l'uso e per un po' di tempo dopo l'uso, poiché diventa molto caldo. Il recipiente va tenuto esclusivamente per la maniglia con entrambe le mani.

GUIDA ALLA COTTURA

La tabella seguente è utile per selezionare le impostazioni di base per gli alimenti che si desidera preparare. **Nota: i tempi di cottura riportati di seguito sono solo indicativi e possono variare a seconda della qualità e della quantità di patate utilizzate. Per gli altri alimenti, la dimensione, la forma e la marca possono influire sui risultati. Pertanto, potrebbe essere necessario regolare leggermente il tempo di cottura.**

NOTA per patate e patatine fritte

- Limitare la temperatura di frittura a 180°C.
- Controllare la cottura. Non mangiare cibi bruciati.
- Si consiglia di friggere fino a ottenere un colore leggermente dorato anziché marrone.
- Conservare le patate fresche in un ambiente con temperatura superiore a 8°C.
- Prima di cucinare, mettere a bagno le patate fresche per 20 minuti per ridurre la quantità di amido.

							i
Patate e patatine fritte							
Patatine fritte surgelate (10 mm x 10 mm)	1000 g		35 min	180°C			Agitare 2 volte
Patatine fritte fatte in casa (8 x 8 mm)	1000 g		35 min	180°C			Aggiungere 1 cucchiaio di olio + agitare 2 volte
Patate surgelate a spicchi	1000 g		35 min	180°C			Aggiungere 1 cucchiaio di olio + agitare 2 volte
Carne e pollame							
Filetti di petto di pollo (dissosati)	500 - 900 g		20 - 25 min	180°C			Girare a metà cottura
Cosce di pollo	1500 g		25 min	200°C			
Pancetta/Pancetta di manzo	8 fette		8 min	180°C			
Salsiccia	10 pezzi		25 min	200°C			Girare a metà cottura
Pesce							
Filetto di salmone	6 pezzi (150g/pezzi)		8 min	200°C			
Gamberetti	12 pezzi		7 min	140°C			
Spuntini							
Crocchette di pollo surgelate	700 g		15 min	200°C			
Ali di pollo	800 g		16 min	200°C			
Bastoncini al formaggio surgelati	750 g		16 min	200°C			
Pizza		FROZEN PIZZA	10 min	200°C			
Pizza fresca	Diametro 26 cm	FRESH PIZZA	6 min	220°C			
Pizza fatta in casa		FRESH PIZZA	10 min	200°C			
Verdure							
Nemi	18 pezzi (900 g)		10 min	200°C			
Cavolfiore (cime)	800 g		20 min	180°C			
Zucchine	600 g		10 min	200°C			
Cottura al forno							
Biscotti	9 pezzi		9-11 min	180°C			
Disidratazione							
Mela a fette	1-2 pezzi		4 h	70°C			

*Agitare a metà cottura

IMPORTANTE: per evitare di danneggiare l'apparecchio, non superare mai le quantità massime di ingredienti e liquidi indicate nel manuale di istruzioni e nella ricette. Quando si utilizzano impasti che lievitano (ad esempio per torte, quiche o muffin) il piatto da forno non deve essere riempito oltre la metà.

SUGGERIMENTI

- Gli alimenti più piccoli richiedono solitamente un tempo di cottura leggermente più breve rispetto agli alimenti di dimensioni maggiori.
- Agitando gli alimenti a metà cottura, si ottiene un risultato migliore e si evita una cottura non omogenea.
- Per rendere le patate ancora più croccanti, provare ad aggiungere una piccola quantità di olio prima di cuocerle e agitarle per coprirle in modo uniforme. Consigliamo 14 ml di olio.
- Gli snack che possono essere cucinati in forno possono essere cucinati anche nell'apparecchio.
- La quantità ottimale consigliata per la cottura delle patatine fritte è 700 grammi.
- Utilizzare la pasta sfoglia e la pasta frolla pronte per preparare snack ripieni in modo rapido e semplice.
- Posizionare una teglia da forno nella ciotola dell'apparecchio se si desidera cuocere una torta o una quiche o se si desidera friggere alimenti delicati o farciti. Si può usare una teglia da forno in silicone, acciaio inox, alluminio, terracotta.
- L'apparecchio può anche essere utilizzato per riscaldare gli alimenti. Per riscaldare gli alimenti, impostare la temperatura su 160 °C per un massimo di 10 minuti. Il tempo di cottura può essere regolato in base alla quantità di alimenti in modo da riscaldarli completamente.

PATATINE FATTE IN CASA

Se si desidera preparare patatine fatte in casa, seguire i passaggi riportati di seguito.

1. Scegliere una varietà di patate adatta alla frittura. Pelare le patate e tagliarle in patatine di uguale spessore.
2. Immergere le patatine in una ciotola di acqua fredda per almeno 30 minuti, scolarle e asciugarle con un canovaccio pulito e altamente assorbente. Quindi tamponarle con carta da cucina. Le patatine devono essere completamente asciutte prima della cottura.
3. Versare 1 cucchiaio di olio (vegetale, di girasole o di oliva) in un recipiente asciutto, mettere le patatine sopra e mescolarle fino a ungerle completamente.
4. Togliere le patatine dalla ciotola con le dita o con un utensile da cucina in modo che l'olio in eccesso rimanga all'interno della ciotola. Versare le patatine nel recipiente.
Nota: non versare la ciotola con le patatine unte direttamente nel recipiente in una sola volta, altrimenti l'olio in eccesso finirà sul fondo del recipiente.
5. Friggere le patatine seguendo le istruzioni nella sezione Guida alla cottura.

PULIZIA

Pulire l'apparecchio dopo ogni utilizzo.

Il cestello ha un rivestimento antiaderente. Non utilizzare utensili da cucina in metallo o materiali abrasivi per la pulizia, poiché ciò potrebbe danneggiare il rivestimento antiaderente.

1. Rimuovere la spina dalla presa di corrente e lasciare raffreddare l'apparecchio.
Nota: rimuovere il recipiente per far raffreddare l'apparecchio più rapidamente.

2. Pulire la parte esterna dell'apparecchio con un panno umido.
3. Pulire la griglia con acqua calda, un po' di detersivo per piatti e una spugna non abrasiva. È possibile utilizzare un liquido sgrassante per rimuovere eventuali residui di sporco.

Nota: Il cestello è lavabile in lavastoviglie.

Suggerimento: se la sporczia rimane attaccata sul fondo del recipiente e sulla griglia, riempirli con acqua calda e del detersivo per piatti. Lasciare il recipiente e la griglia immersi per circa 10 minuti, quindi sciacquarli e asciugarli.

4. Pulire l'interno dell'apparecchio con acqua calda e un panno umido.
5. Pulire l'elemento riscaldante con una spazzola asciutta per rimuovere eventuali residui di cibo.
6. Non immergere l'apparecchio in acqua o in altri liquidi.

CONSERVAZIONE

1. Scollegare l'apparecchio dalla presa di corrente e lasciarlo raffreddare.
2. Assicurarci che tutte le parti siano pulite e asciutte.

GARANZIA E ASSISTENZA

Per assistenza, informazioni o se si verificano problemi, visitare il sito Web dell'azienda produttrice oppure contattare il centro assistenza clienti del proprio paese. Il numero di telefono è riportato nell'opuscolo della garanzia internazionale. Se nel proprio paese non è presente un centro assistenza clienti, rivolgersi al rivenditore di zona.

RISOLUZIONE DEI PROBLEMI

In caso di problemi con l'apparecchio, visitare il sito Web dell'azienda produttrice (vedere la pagina di copertina del presente Manuale) per un elenco delle domande frequenti oppure contattare il centro assistenza clienti del proprio paese.

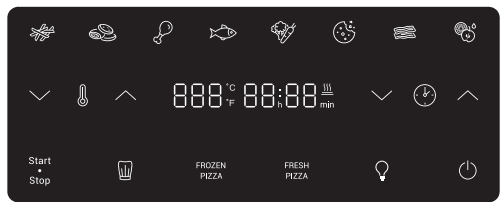
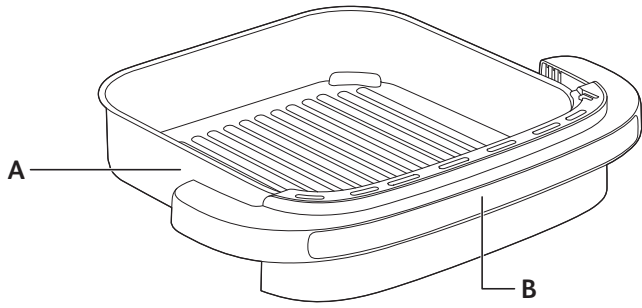
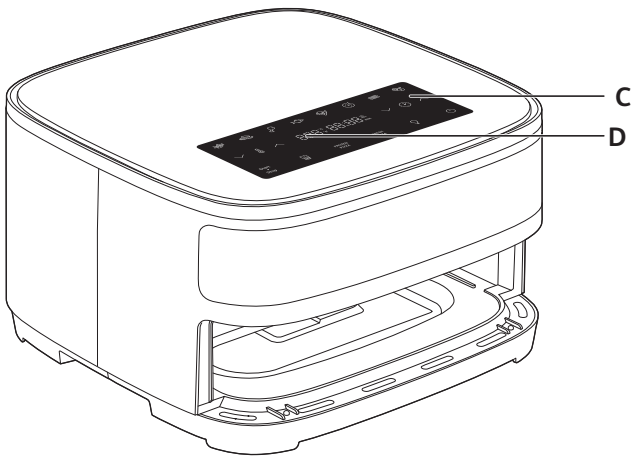

ΠΕΡΙΓΡΑΦΗ

- A. μπολ
B. Λαβή μπολ
C. Ψηφιακή οθόνη αφής
D. Οθόνη χρόνου/θερμοκρασίας

ΑΥΤΟΜΑΤΕΣ ΛΕΙΤΟΥΡΓΙΕΣ ΜΑΓΕΙΡΕΜΑΤΟΣ

 Τηγανητές πατάτες

 Κοτομπουκιές

 Κοντοσούβλια κοτόπουλου

 Ψάρι

 Λαχανικά

 Cookies

 Μπέικιν/βοδινό μπέικιν

 Αποξηράνση

 Κατεψυγμένη πίτσα

 Φρέσκια πίτσα

ΠΡΙΝ ΑΠΟ ΤΗΝ ΠΡΩΤΗ ΧΡΗΣΗ

Διαβάστε πρώτα αυτές τις οδηγίες ασφαλείας και το εγχειρίδιο και φυλάξτε τα σε ασφαλές σημείο.

1. Αφαιρέστε όλα τα υλικά της συσκευασίας, Αφαιρέστε όλα τα αυτοκόλλητα από τη συσκευή.
2. Καθαρίστε κάδο και με ζεστό νερό, λίγο υγρό σαπουνί και ένα μαλακό σφουγγάρι.

Σημείωση: Οι κάδοι και πλένονται στο πλυντήριο πιάτων.

3. Σκουπίστε το εσωτερικό και το εξωτερικό της συσκευής με ένα βρεγμένο πανί. Η συσκευή λειτουργεί με ζεστό αέρα. Μην γεμίζετε τον κάδο με λάδι ή λίπος για τηγάνισμα.

ΠΡΟΕΤΟΙΜΑΣΙΑ ΓΙΑ ΧΡΗΣΗ

1. Τοποθετήστε τη συσκευή σε μια επίπεδη, σταθερή και πυρίμαχη επιφάνεια, μακριά από μέρη όπου μπορεί να πεταχτεί νερό.
2. **Μην γεμίζετε το συρτάρι με λάδι ή άλλο υγρό.**
Μην τοποθετείτε τίποτα πάνω στη συσκευή. Κάτι τέτοιο εμποδίζει την κυκλοφορία του αέρα και επηρεάζει το αποτέλεσμα του τηγανίσματος σε ζεστό αέρα.

ΣΗΜΑΝΤΙΚΟ: Για να μην υπερθερμανθεί η συσκευή, μην την τοποθετείτε σε γωνίες ή κάτω από ντουλάπια στερεωμένα στον τοίχο. Θα πρέπει να αφήνετε ένα κενό τουλάχιστον 15 εκ. γύρω από τη συσκευή, ώστε να κυκλοφορεί ο αέρας.











ΧΡΗΣΗ ΜΟΝΟΣ ΕΝΟΣ ΚΑΔΟΥ ΤΗΣ ΣΥΣΚΕΥΗΣ

Η συσκευή μπορεί να προετοιμάσει μια μεγάλη ποικιλία συνταγών. Οι χρόνοι μαγειρέματος για βασικά πιάτα παρέχονται στην ενότητα «Οδηγός μαγειρικής». Οι ηλεκτρονικές συνταγές σας βοηθούν να εξοικειωθείτε με τη συσκευή.









1. Βάλτε το καλώδιο τροφοδοσίας ρεύματος στην πρίζα.
2. Τοποθετήστε το φαγητό στον κάδο.

Σημείωση: Ποτέ να μην υπερβαίνετε τη μέγιστη ποσότητα που αναγράφεται στον πίνακα (ανατρέξτε στην ενότητα «Οδηγός μαγειρικής»), καθώς κάτι τέτοιο μπορεί να επηρεάσει το τελικό αποτέλεσμα.

3. Σπρώξτε ξανά τον κάδο μέσα στη συσκευή.
4. Για να ξεκινήσετε το μαγείρεμα, πρέπει να επιλέξετε την προκαθορισμένη λειτουργία μαγειρέματος.







- Πατήστε το κουμπί  για να εμφανίσετε τη λειτουργία μαγειρέματος.
 - Στη συνέχεια, πατήστε το κουμπί  στην οθόνη για να επιλέξετε την επιθυμητή λειτουργία μαγειρέματος (αυτές οι λειτουργίες περιγράφονται λεπτομερώς στην ενότητα «Οδηγός μαγειρικής»).
 - Μπορείτε να αλλάξετε τον χρόνο μαγειρέματος πατώντας το  και να τον προσαρμόσετε με τα κουμπιά  και  χρονοδιακόπτης μπορεί να ρυθμιστεί μεταξύ 0 και 60 λεπτών.
 - Ρυθμίστε τη θερμοκρασία  με τα κουμπιά  και  στην ψηφιακή οθόνη. Ο θερμοστάτης ρυθμίζεται από 40°C έως 230°C.
 - Πατήστε το κουμπί  για να ξεκινήσει το μαγείρεμα με τις επιλεγμένες ρυθμίσεις θερμοκρασίας και χρόνου.
 - Το μαγείρεμα ξεκινά. Ο χρόνος μαγειρέματος που απομένει εμφανίζεται στην οθόνη.
5. Κατά τη διάρκεια του μαγειρέματος, η εσωτερική λυχνία επιτρέπει τον έλεγχο της διαδικασίας του μαγειρέματος. Πιέστε  για να ανάψει. Πατήστε ξανά για να σβήσει.
 6. Κάποιες συνταγές απαιτούν το ανακάτεμα του φαγητού στη μέση του χρόνου μαγειρέματος για βέλτιστα αποτελέσματα μαγειρέματος (ανατρέξτε την ενότητα «Οδηγός μαγειρικής»). Για να ανακατέψετε το φαγητό, κρατήστε τη χειρολαβή για να τραβήξετε το μπολ από τη συσκευή και ανακατέψτε. Στη συνέχεια, σπρώξτε ξανά το μπολ μέσα στη συσκευή και το μαγείρεμα θα ξεκινήσει και πάλι αυτόματα.
 7. Όταν ακούσετε την ηχητική ειδοποίηση του χρονοδιακόπτη, η επιλεγμένη ώρα μαγειρέματος έχει ολοκληρωθεί. Βγάλτε το μπολ από τη συσκευή και τοποθετήστε το σε μια πυρίμαχη επιφάνεια.
 8. Ελέγξτε αν το φαγητό έχει γίνει.
Αν το φαγητό δεν έχει γίνει ακόμα, απλά σύρετε το μπολ μαγειρέματος πίσω στη συσκευή και ρυθμίστε τον χρονοδιακόπτη για λίγα επιπλέον λεπτά λειτουργίας.
 9. Όταν το φαγητό μαγειρευτεί, αφαιρέστε το μπολ. Για να βγάλετε το φαγητό από το μπολ, χρησιμοποιήστε μια λαβίδα.
- Προσοχή: Μετά το μαγείρεμα, το μπολ, και το φαγητό θα καίει. Μην αγγίζετε το μπολ κατά τη χρήση και για λίγο χρόνο μετά τη χρήση, γιατί καίει. Να κρατάτε το μπολ μόνο από τη χειρολαβή.**
10. Μόλις ολοκληρωθεί το μαγείρεμα μιας ποσότητας φαγητού, η συσκευή είναι έτοιμη στη στιγμή για το μαγείρεμα της επόμενης ποσότητας φαγητού.

ΠΙΤΣΑ

1. Τοποθετήστε το φαγητό στον κάδο, Σπρώξτε ξανά τον κάδο μέσα στη συσκευή.
2. Πατήστε το , και, στη συνέχεια, πατήστε το  ή .
3. Επιλέξτε τον απαιτούμενο χρόνο μαγειρέματος πατώντας τα κουμπιά  και  Ρυθμίστε τη θερμοκρασία με τα κουμπιά  και  στην ψηφιακή οθόνη.
4. Πατήστε το κουμπί «ENAPΞH»  για να ξεκινήσει το μαγείρεμα. Η θερμοκρασία και ο υπολειπόμενος χρόνος μαγειρέματος θα εμφανίζονται εναλλάξ στην οθόνη.
5. Όταν ακούσετε την ηχητική ειδοποίηση του χρονοδιακόπτη, το μαγείρεμα έχει ολοκληρωθεί. Βγάλτε τον κάδο από τη συσκευή και τοποθετήστε τον σε μια πυρίμαχη επιφάνεια.
6. Ελέγξτε αν το φαγητό έχει γίνει. Αν το φαγητό δεν έχει γίνει ακόμα, απλά σύρετε το μπολ μαγειρέματος πίσω στη συσκευή και ρυθμίστε τον χρονοδιακόπτη για λίγα επιπλέον λεπτά λειτουργίας.
7. Όταν το φαγητό μαγειρευτεί, αφαιρέστε το μπολ.

Προσοχή: Μετά το μαγείρεμα, το μπολ, η και το φαγητό θα καίνε. Μην αγγίζετε το μπολ κατά τη χρήση και για λίγο χρόνο μετά τη χρήση, γιατί καίει. Να κρατάτε το μπολ μόνο από τη χειρολαβή με τα δύο χέρια.

ΑΠΟΞΗΡΑΝΣΗ

1. Τοποθετήστε το φαγητό στην πλάκα ψησίματος και επανατοποθετήστε το μπολ στη συσκευή, Τοποθετήστε το φαγητό στον κάδο.
2. Πατήστε , στη συνέχεια ρυθμίστε τη θερμοκρασία  πατώντας τα κουμπιά  και  και - έως τη θερμοκρασία 70°C στην ψηφιακή οθόνη.
3. Στη συνέχεια, ρυθμίστε τον επιθυμητό χρόνο μαγειρέματος πατώντας το κουμπί  και ρυθμίζοντας την ώρα με τα κουμπιά  και . Μπορείτε να ρυθμίσετε τον χρόνο από 1 ώρα έως 12 ώρες.
4. Πατήστε το κουμπί «ENAPΞH» ^{Start} _{Stop} για να ξεκινήσει η διαδικασία αποξήρανσης. Η επιλεγμένη θερμοκρασία και ο υπολειπόμενος χρόνος μαγειρέματος θα εμφανίζονται αλλάζοντας στην οθόνη.
5. Όταν ακούσετε την ηχητική ειδοποίηση του χρονοδιακόπτη, το μαγείρεμα έχει ολοκληρωθεί. Βγάλτε το μπολ από τη συσκευή και τοποθετήστε τον σε μια πυρίμαχη επιφάνεια.
6. Ελέγξτε αν το φαγητό έχει γίνει. Αν το φαγητό δεν έχει γίνει ακόμα, απλά σύρετε το μπολ μαγειρέματος πίσω στη συσκευή και ρυθμίστε τον χρονοδιακόπτη για λίγα επιπλέον λεπτά λειτουργίας.
7. Όταν το φαγητό μαγειρευτεί, αφαιρέστε το μπολ. Για να βγάλετε το φαγητό από το μπολ, χρησιμοποιήστε μια λαβίδα.

Προσοχή : Μετά το μαγείρεμα, το μπολ, η και το φαγητό θα καίνε. Μην αγγίζετε το μπολ κατά τη χρήση και για λίγο χρόνο μετά τη χρήση, γιατί καίει. Να κρατάτε το μπολ μόνο από τη χειρολαβή με τα δύο χέρια.

































ΟΔΗΓΟΣ ΜΑΓΕΙΡΙΚΗΣ

Ο παρακάτω πίνακας σας βοηθάει να επιλέξετε τις βασικές ρυθμίσεις για τα πιάτα που θέλετε να δημιουργήσετε.

Σημείωση: Οι παρακάτω χρόνοι μαγειρέματος είναι απλώς ενδεικτικοί και μπορεί να διαφέρουν ανάλογα με την ποικιλία και τη δόση από πατάτες που χρησιμοποιείτε. Για άλλες τροφές, το μέγεθος, το σχήμα και η μέρκα μπορεί να επηρεάσουν τα αποτελέσματα. Επομένως, ενδέχεται να πρέπει να προσαρμόσετε ελαφρώς τον χρόνο μαγειρέματος.

ΣΗΜΕΙΩΣΗ για τις πατάτες και τις τηγανητές πατάτες

- Περιορίστε τη θερμοκρασία τηγανίσματος στους 180°C.
- Ελέγξτε το μαγείρεμα. Μην τρώτε καμένα τρόφιμα.
- Σας συμβουλεύουμε να τηγανίζετε μέχρι να αποκτήσουν ελαφρώς χρυσαφί χρώμα αντί για καφέ χρώμα.
- Αποθηκεύστε τις φρέσκες πατάτες σας σε χώρο πάνω από 8°C.
- Πριν από το μαγείρεμα, μουλιάστε τις φρέσκες πατάτες για 20 λεπτά για να μειώσετε τη ποσότητα του αμύλου.

							
Πατάτες και τηγανητές πατάτες							
Κατεψυγμένες τηγανητές πατάτες (10 mm x 10 mm)	1000 g		35 min	180°C			2 κουνήματα
Σπικικές τηγανιτές πατάτες (8 x 8 mm)	1000 g		35 min	180°C			Προσθέστε 1 κουταλιά της σούπας λάδι + 2 κουνήματα
Κατεψυγμένες κυδωνάτες πατάτες	1000 g		35 min	180°C			Προσθέστε 1 κουταλιά της σούπας λάδι + 2 κουνήματα
Κρέας και πουλερικά							
Στήθος κοτόπουλο (χωρίς κόκαλα)	500 - 900 g		20 - 25 min	180°C			Αναποδογυρίστε στα μισά του μαγειρέματος
Τυμπανάκια κοτόπουλου	1500 g (12 κομμάτια)		25 min	200°C			
Μπέικον/βοδινό μπέικον	8 φέτες		8 min	180°C			
Λουκάνικο	10 κομμάτια		25 min	200°C			Αναποδογυρίστε στα μισά του μαγειρέματος
Ψάρι							
Φιλέτο σολομού	6 κομμάτια		8 min	200°C			
Γαρίδες	12 κομμάτια		7 min	140°C			
Σνακ							
Κατεψυγμένες κοτοπουκιές	700 g		15 min	200°C			
Φτερούγες κοτόπουλου	800 g		16 min	200°C			
Παγωμένες τυροκροκέτες	750 g		16 min	200°C			
Παγωμένη Πίτσα	Διάμετρος 26 cm	FROZEN PIZZA	10 min	200°C			
Φρέσκια πίτσα		FRESH PIZZA	6 min	220°C			
Σπιτική πίτσα		FRESH PIZZA	10 min	200°C			
Λαχανικά							
Nems	18 κομμάτια (900 g)		10 min	200°C			
Κουνουπίδι (κορυφές)	800 g		20 min	180°C			
Κολοκυθάκια	600 g		10 min	200°C			
Ψήσιμο							
Μπισκότα	9 κομμάτια		9 - 11 min	180°C			
Αποξήρανση							
Μήλα σε φέτες	1-2 κομμάτια		4 h	70°C			

* Ανακινήστε στη μέση του μαγειρέματος.

ΣΗΜΑΝΤΙΚΟ: Για να αποφύγετε την πρόκληση φθοράς στη συσκευή σας, ποτέ να μην υπερβείτε τις μέγιστες ποσότητες συστατικών και υγρών που αναγράφονται στο εγχειρίδιο οδηγιών και στις συνταγές. Όταν χρησιμοποιείτε μείγματα που φουσκώνουν (όπως για κέικ, κικ ή μάφιν), η φόρμα δεν πρέπει να γεμίζει πάνω από το μισό.

ΣΥΜΒΟΥΛΕΣ

- Οι μικρότερου μεγέθους τροφές απαιτούν κάπως λιγότερο χρόνο μαγειρέματος, συγκριτικά με τις μεγαλύτερου μεγέθους τροφές.
- Η ανακίνηση τροφών μικρότερου μεγέθους στη μέση του μαγειρέματος βελτιώνει το τελικό αποτέλεσμα και μπορεί να αποτρέψει το ανομοιόμορφο μαγείρεμα.
- Για να κάνετε τις πατάτες ιδιαίτερα τραγανές, δοκιμάστε να προσθέσετε μια μικρή ποσότητα λαδιού πριν από το μαγείρεμα και ανακατέψτε για να καλύψετε ομοιόμορφα τις πατάτες. Συνιστούμε 14ml λάδι.
- Η βέλτιστη προτεινόμενη ποσότητα για μαγείρεμα τηγανητής πατάτας είναι τα 700 γραμμάρια.
- Χρησιμοποιήστε έτοιμη ζύμη σφολιάτας, κουρού ή άλλη για να φτιάξετε γεμιστά σνακ, εύκολα και γρήγορα.
- Τοποθετήστε ένα ταψί στο μπολ της συσκευής εάν θέλετε να ψήσετε ένα κέικ ή μία τάρτα ή εάν θέλετε να τηγανίσετε ευαίσθητα ή γεμιστά υλικά. Μπορείτε να χρησιμοποιήσετε ένα πυρίμαχο σκεύος από σιλκόνη, ανοξείδωτο ασάλι, αλουμίνιο ή τερακότα.
- Μπορείτε επίσης να χρησιμοποιήσετε τη συσκευή για να ξαναζεστάνετε φαγητό. Για να ζεστάνετε φαγητό, ρυθμίστε τη θερμοκρασία στους 160 °C για έως και 10 λεπτά. Ο χρόνος μαγειρέματος μπορεί να προσαρμοστεί ανάλογα με την ποσότητα του φαγητού για να ξαναζεστάνετε πλήρως το φαγητό.

ΣΠΙΤΙΚΕΣ ΤΗΓΑΝΗΤΕΣ ΠΑΤΑΤΕΣ

Αν θέλετε να φτιάξετε σπιτικές τηγανητές πατάτες, ακολουθήστε τα παρακάτω βήματα.

1. Επιλέξτε μια ποικιλία πατάτας που ενδείκνυται για τηγάνισμα. Ξεφλουδίστε τις πατάτες και κόψτε τις σε φέτες ίδιου πάχους.
2. Μουλιάστε τα μασατουνάκια πατάτας σε ένα μπολ με κρύο νερό για τουλάχιστον 30 λεπτά, στραγγίξτε τα και στεγνώστε τα με μια καθαρή, πολύ απορροφητική πετσέτα. Στη συνέχεια, ταμπονάρετε με χαρτί κουζίνας. Οι πατάτες πρέπει να είναι πολύ καλά στεγνωμένες πριν από το μαγείρεμα.
3. Ρίξτε 1 κουταλιά σούπας λάδι (φυτικό, ηλιέλαιο ή ελαιόλαδο) σε ένα στεγνό μπολ, προσθέστε τις κομμένες πατάτες και ανακατέψτε μέχρι να καλυφθούν με το λάδι.
4. Βγάλτε τις κομμένες πατάτες από το μπολ με το χέρι ή με ένα κουζινικό σκεύος, έτσι ώστε το επιπλέον λάδι να παραμείνει στο μπολ. Τοποθετήστε τις κομμένες πατάτες στο μπολ.
Σημείωση: Μην αδειάσετε το δοχείο με τις κομμένες πατάτες απευθείας στο μπολ, γιατί το επιπλέον λάδι θα καταλήξει στον πυθμένα του μπολ.
5. Τηγανίστε τις πατάτες σύμφωνα με τις οδηγίες στην ενότητα «Οδηγός μαγειρικής».

ΚΑΘΑΡΙΣΜΟΣ

Καθαρίστε τη συσκευή μετά από κάθε χρήση.

Το μπολ και αντικολητική επίστρωση. Μην χρησιμοποιείτε μεταλλικά κουζινικά σκεύη ή λειαντικά προϊόντα καθαρισμού για να τα καθαρίσετε, καθώς κάτι τέτοιο μπορεί να φθείρει την αντικολητική επικάλυψη.

1. Βγάλτε το καλώδιο από την πρίζα και αφήστε τη συσκευή να κρυώσει.
Σημείωση: Αφαιρέστε το μπολ για να αφήσετε τη συσκευή να κρυώσει πιο γρήγορα.
2. Σκουπίστε το εξωτερικό της συσκευής με ένα βρεγμένο πανί.
3. Καθαρίστε το μπολ και με ζεστό νερό, λίγο υγρό σαπούνι και ένα μαλακό σφουγγάρι. Μπορείτε να χρησιμοποιήσετε απολιπαντικό υγρό για να αφαιρέσετε τυχόν υπολείμματα βρωμιάς.
Σημείωση: Το μπολ και η σχάρα πλένονται στο πλυντήριο πιάτων.
Συμβουλή: Αν έχουν κολλήσει υπολείμματα στον πυθμένα του μπολ και στη σχάρα, γεμίστε τα με ζεστό νερό και λίγο υγρό σαπούνι. Αφήστε το μπολ και τη σχάρα να μουλιάσουν για περίπου 10 λεπτά. Στη συνέχεια, ξεπλύνετε και σκουπίστε.
4. Σκουπίστε το εσωτερικό της συσκευής με ζεστό νερό και ένα υγρό πανί.
5. Καθαρίστε το θερμοαντικό στοιχείο με ένα στεγνό βουρτσάκι καθαρισμού για να απομακρύνετε τυχόν υπολείμματα φαγητού.
6. Μη βυθίζετε τη συσκευή σε νερό ή άλλο υγρό.

ΑΠΟΘΗΚΕΥΣΗ

1. Βγάλτε από την πρίζα τη συσκευή και αφήστε την να κρυώσει.
2. Βεβαιωθείτε ότι όλα τα μέρη είναι καθαρά και στεγνά.

ΕΓΓΥΗΣΗ ΚΑΙ ΣΕΡΒΙΣ

Αν χρειαστείτε σέρβις ή πληροφορίες ή αν έχετε κάποιο πρόβλημα, επισκεφθείτε τον ιστότοπο της επωνυμίας ή επικοινωνήστε με το κέντρο εξυπηρέτησης καταναλωτών της επωνυμίας στη χώρα σας. Μπορείτε να βρείτε τον αριθμό τηλεφώνου στο φυλλάδιο διεθνούς εγγύησης. Αν δεν υπάρχει κέντρο εξυπηρέτησης καταναλωτών στη χώρα σας, επισκεφθείτε τον τοπικό αντιπρόσωπο της επωνυμίας.

ΑΝΤΙΜΕΤΩΠΙΣΗ ΠΡΟΒΛΗΜΑΤΩΝ

Αν συναντήσετε προβλήματα με τη συσκευή, επισκεφθείτε τον ιστότοπο της επωνυμίας (βλ. εξώφυλλο αυτού του εγχειριδίου) για να δείτε τον κατάλογο συχνών ερωτήσεων ή επικοινωνήστε με το κέντρο εξυπηρέτησης καταναλωτών στη χώρα σας.

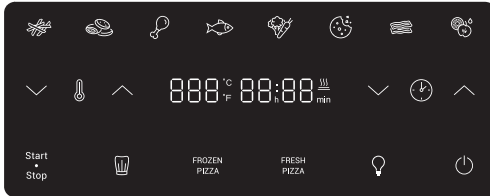
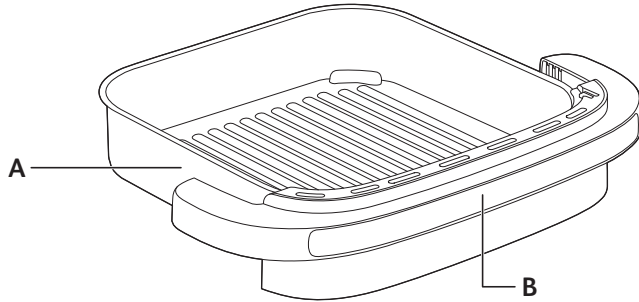
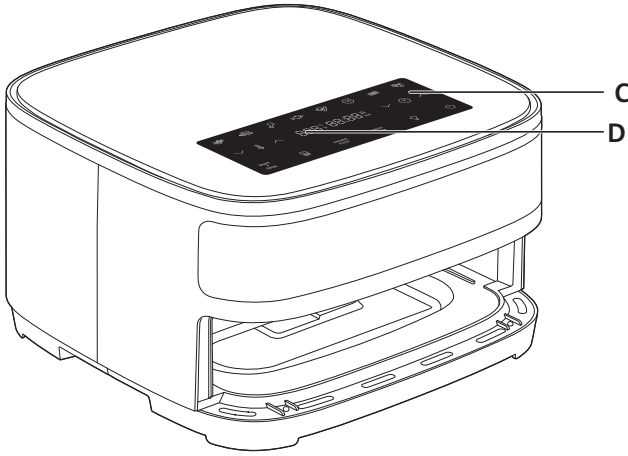

AÇIKLAMA

A. Hazne

B. Hazne kolu

C. Dijital dokunmatik ekran paneli

D. Zaman/sıcaklık ekranı

OTOMATİK PIŞİRME MODLARI



Kızartma



Tavuk nugget



Tavuk butları



Balık



Sebze



Çerezler



Domuz pastırması/dana pastırması



Kurutma



Dondurulmuş pizza



Taze pizza

İLK KULLANIMDAN ÖNCE

Öncelikle güvenlik talimatlarını ve kılavuzu okuyun ve bunları güvenli bir yerde saklayın.

1. Tüm ambalaj malzemelerini çıkarın ve tüm cihaz etiketleri.
2. Hazneyi biraz bulaşık deterjanı ve aşındırıcı olmayan bir sünger ile iyice temizleyin.
Not: Hazneli bulaşık makinesinde yıkanabilir.
3. Cihazın içini ve dışını nemli bir bezle silin. Cihaz sıcak hava üreterek çalışır. Hazneyi katı ya da sıvı kızartma yağı ile doldurmayın.

KULLANMADAN ÖNCE HAZIRLIK

1. Cihazı, su sıçrayabilecek yerlerin uzağında olan, düz, sabit ve ısıya dayanıklı bir çalışma yüzeyinin üzerine yerleştirin.
2. Hazneyi yağ veya başka sıvılarla doldurmayın.
Cihazın üzerine herhangi bir şey koymayın. Bu hava akışını kesintiye uğratar ve sıcak hava ile kızartmanın sonucunu etkiler.









ÖNEMLİ: Cihazın aşırı ısınmasını önlemek için, bir köşeye veya bir duvar dolabının altına koymayın. Havanın akışının sağlanması için cihazın etrafında en az 15 cm boşluk bırakılmalıdır.

CİHAZIN YALNIZCA BİR HAZNESİNİ KULLANMA







Cihaz birçok çeşit tarifi pişirebilir. Ana yemekler için pişirme süreleri «Yemek Pişirme Kılavuzu» bölümünde verilmiştir. Çevrimiçi tarifler, cihazı tanımanıza yardımcı olur.

1. Elektrik kablosunu bir elektrik prizine takın.
2. İlk yiyeceği hazne.
Not: Nihai sonucun kalitesini etkileyebileceğinden, tabloda belirtilen maksimum miktarı asla aşmayın («Yemek Pişirme Kılavuzu» bölümüne bakın).
3. Hazneyi kaydırarak tekrar cihaza takın.
4. Pişirmeye başlamak için önceden ayarlanmış pişirme modunu seçmelisiniz.









- Pişirme modunu görüntülemek için düğmesine basın.
- Arzu edilen pişirme modunu seçmek için ekrandaki düğmesine basın
(Bu modlar «Yemek Pişirme Kılavuzu» bölümünde ayrıntılı olarak anlatılmıştır).

-  düğmesine basarak pişirme süresini değiştirebilir,  ve  düğmeleriyle ayarlayabilirsiniz. Zamanlayıcı 0 ile 60 dakika arasında ayarlanabilir.
- Dijital ekrandaki   ve  düğmelerini kullanarak sıcaklığı ayarlayın. Termostat sıcaklığı 40 - 230°C arasında değişir.
- Pişirmeyi seçilen sıcaklık ve zaman ayarlarıyla başlatmak için  düğmesine basın.
- Pişirme başlar. Kalan pişirme süresi ekranda görüntülenir.
- Seçilen sıcaklık ve saat ayarlarıyla pişirmeye başlamak için Başlat düğmesine basın. Pişirme başlar. Ekrandaki göstergede sıcaklık ve kalan pişirme süresi sırayla görünecektir.
- 5. Pişirme sırasında, iç ışık pişirme işleminin kontrol edilmesini sağlar. Yanması için  tuşuna basın. Kapatmak için tekrar basın.
- 6. En iyi pişirme sonuçları için bazı yiyeceklerin pişirme süresinin ortasında karıştırılması gerekir («Yemek Pişirme Kılavuzu» bölümüne bakın.). Yiyecekleri karıştırmak için hazneyi sapından tutarak cihazdan çıkarın ve sallayın. Ardından hazneyi tekrar cihaza takın. Pişirme işlemi otomatik olarak yeniden başlar.
- 7. Zamanlayıcı çaldığında, ayarlanan pişirme süresi sona ermiş olur. Hazneyi cihazdan çıkarın ve ısıya dayanıklı bir yüzeyin üzerine yerleştirin.
- 8. Yiyeceklerin hazır olup olmadığını kontrol edin. Yiyecekler henüz hazır değilse hazneyi tekrar cihazın içine kaydırın ve zamanlayıcıda ekstra birkaç dakika daha ayarlayın.
- 9. Yiyecekler piştiğinde hazneyi çıkarın. Yiyecekleri hazneden çıkarmak için maşa kullanın. **Dikkat: Pişirme sonrasında hazne, ızgara ve yiyecek çok sıcaktır. Çok ısındığından kullanım esnasında veya kullanımdan sonra bir süre için hazneye dokunmayın. Hazneyi sadece sapından tutun.**
- 10. Bir parti yiyeceğin pişirilmesi tamamlanır tamamlanmaz, cihaz bir sonraki partiyi pişirmek için hazır olur.

PIZZA

1. Pizzayı kaseye yerleştirin ve kaseyi tekrar cihazın içine kaydırın.
2.  düğmesine ve ardından ekranda  veya  düğmesine basın.
3.  ve  düğmelerine basarak gerekli pişirme süresini seçin («Yemek Pişirme Kılavuzu» bölümüne bakın).
4. Pişirmeyi başlatmak için Başlat düğmesine  basın. Ekrandaki göstergede sıcaklık ve kalan pişirme süresi sırayla görünecektir. **Not: Et pişiriyorsanız pişirme süresinin ortasında parçaları çevirmeniz gerekir. Yiyeceklerdeki fazla yağ haznenin dibinde toplanır.**
5. Zamanlayıcı çaldığında, pişirme sona ermiş olur. Hazneyi cihazdan çıkarın ve ısıya dayanıklı bir yüzeyin üzerine yerleştirin.
6. Yiyeceklerin hazır olup olmadığını kontrol edin. Yiyecekler henüz hazır değilse hazneyi tekrar cihazın içine kaydırın ve zamanlayıcıda ekstra birkaç dakika daha ayarlayın.
7. Yiyecekler piştiğinde hazneyi çıkarın. Yiyecekleri hazneden çıkarmak için maşa kullanın. **Dikkat: Pişirme sonrasında hazne, ızgara ve yiyecek çok sıcaktır. Çok ısındığından kullanım esnasında veya kullanımdan sonra bir süre için hazneye dokunmayın. Hazneyi sadece sapından tutun.**

KURUTMA

1. Yiyecekleri ızgara plakasına yerleştirin ve hazneyi cihaza geri takın. İlk yiyeceği hazne.
2. Şu düğmeye basın: . Ardından dijital  ekranda  ve  düğmelerine basarak sıcaklığı 70°C'ye ayarlayın.
3. Ardından  düğmesine basıp  ve  düğmeleriyle süreyi ayarlayarak istenen pişirme süresini belirleyin. Zamanlamayı 1 saatten 12 saate kadar ayarlayabilirsiniz.
4. Kurutma işlemini başlatmak için  Başlat düğmesine basın. Ekrandaki göstergede seçilen sıcaklık ve kalan pişirme süresi sırayla görüntülenir.
5. Zamanlayıcı çaldığında, pişirme sona ermiş olur. Hazneyi cihazdan çıkarın ve ısıya dayanıklı bir yüzeye yerleştirin.
6. Yiyeceklerin hazır olup olmadığını kontrol edin. Yiyecekler henüz hazır değilse hazneyi tekrar cihazın içine kaydırın ve zamanlayıcıda ekstra birkaç dakika daha ayarlayın.
7. Yiyecekler piştiğinde hazneyi çıkarın. Yiyecekleri hazneden çıkarmak için maşa kullanın. **Dikkat: Pişirme sonrasında hazne, ızgara ve yiyecek çok sıcaktır. Çok ısındığından kullanım esnasında veya kullanımdan sonra bir süre için hazneye dokunmayın. Hazneyi sadece sapından tutun.**

PIŞİRME KILAVUZU

Aşağıdaki tablo, hazırlamak istediğiniz yiyecekler için temel ayarları yapmanıza yardımcı olur. **Not: Aşağıdaki pişirme süreleri yalnızca bir kılavuz niteliğindedir ve kullanılan patates türüne ve durumuna göre değişiklik gösterebilir. Diğer yiyecekler için boyutlar, şekil ve marka sonuçları etkileyebilir. Bu yüzden pişirme süresini biraz değiştirmeniz gerekebilir.**

Patates ve Patates Kızartması için Not

- Kızartma sıcaklığını 180°C ile sınırlayın.
- Pişirmeyi kontrol edin. Yanmış yiyecekleri yemeyin
- Kahverengi yerine hafif altın renginde kızartmanızı tavsiye ederiz.
- Taze patateslerinizi 8°C'nin üzerindeki bir odada saklayın.
- Pişirmeden önce nişasta miktarını azaltmak için taze patatesleri 20 dakika bekletin.

Patates ve kızartmalar						
Dondurulmuş kızartmalar (10 mm x 10 mm)	1000 g		35 min	180°C		2 sallama
Ev yapımı patates kızartması (8 x 8 mm)	1000 g		35 min	180°C		1 yemek kaşığı yağ ekleyin + 2 sallama
Dondurulmuş patates dilimleri	1000 g		35 min	180°C		1 yemek kaşığı yağ ekleyin + 2 sallama
Et ve Tavuk						
Tavuk göğsü filetosu (kemiksiz)	500 - 900 g		20 - 25 min	180°C		Pişirme alanının ortasına çevirin
Tavuk butları	1500 g		25 min	200°C		
Domuz pastirması/dana pastirması	8 dilim		8 min	180°C		
Sosis	10 parça		25 min	200°C		Pişirme alanının ortasına çevirin
Balık						
Somon fileto	6 parça (150g/parça)		8 min	200°C		
Karides	12 parça		7 min	140°C		
Atıştırmalıklar						
Dondurulmuş tavuk nugget	700 g		15 min	200°C		
Tavuk kanadı	800 g		16 min	200°C		
Donmuş peynir çubukları	750 g		16 min	200°C		
Dondurulmuş pizza		FROZEN PIZZA	10 min	200°C		
Taze pizza	26cm çap	FRESH PIZZA	6 min	220°C		
Ev yapımı pizza		FRESH PIZZA	10 min	200°C		
Sebze						
Nems	18 parça (900 g)		10 min	200°C		
Karnabahar (üstleri)	800 g		20 min	180°C		
Kabak	600 g		10 min	200°C		
Pişirme						
Kurabiye	9 parça		9-11 min	180°C		
Kurutma						
Sliced apples	1-2 parça		4 h	70°C		

* Pişirme işleminin yarısında sallayın.

ÖNEMLİ: Cihazınıza zarar vermekten kaçınmak için asla kullanma kılavuzunda ve tariflerde belirtilen maksimum malzeme ve sıvı miktarını aşmayın. Kabaran karışımlar (örneğin kek, kiş veya muffin gibi) kullandığınızda fırın kabı yarısından fazla doldurulmamalıdır.

İPUÇLARI

- Daha küçük yiyecekler genellikle daha büyük yiyecekler göre biraz daha kısa sürede pişerler.
- Daha küçük yiyeceklerin pişirme süresinin yarısında sallanması daha iyi bir pişirme sonucu elde edilmesini sağlar ve yiyeceklerin eşit pişmemesini önlemeye yardımcı olabilir.
- Patateslerinizin çıtır çıtır olması için pişirmeden önce az miktarda yağ eklemeyi deneyin ve eşit şekilde kaplamak için sallayın. 14 ml yağ öneririz.
- Fırında pişirilebilecek atıştırmalıklar cihazda da pişirilebilirler.
- Patates kızartması pişirmek için tavsiye edilen ideal miktar 700 gramdır.
- Kolay ve hızlı bir şekilde içi dolu atıştırmalıklar yapmak için hazır puf börek ve tart hamuru kullanın.
- Kek veya kiş pişirmek veya hassas ya da içi doldurulmuş yiyecekleri kızartmak istiyorsanız cihazın haznesine bir fırın kabı yerleştirin. Silikon, paslanmaz çelik, alüminyum ve terakota fırın kabı kullanabilirsiniz.
- Cihazı yiyecekleri yeniden ısıtmak için de kullanabilirsiniz. Yiyecekleri tekrar ısıtmak için sıcaklığı 10 dakikaya kadar 160°C olarak ayarlayın. Yiyeceği tamamen yeniden ısıtmak için pişirme süresi yiyecek miktarına göre ayarlanabilir.

EV YAPIMI PATATES KIZARTMASI YAPMA

Ev yapımı patates kızartması yapmak istiyorsanız aşağıdaki adımları takip edin.

1. Patates kızartması yapmak için tavsiye edilen bir patates çeşidi seçin. Patatesleri soyun ve eşit kalınlıkta patates kızartması şeklinde dilimleyin.
2. Çubuk çubuk doğradığınız patatesleri en az 30 dakika süreyle soğuk su dolu bir kabın içinde bekletin, ardından süzün ve temiz, yüksek emiş gücüne sahip bir kurulum bezi ile kurulayın. Ardından kağıt havluyla kurulayın. Patatesler kızartılmadan önce iyice kuru olmalıdır.
3. Kuru bir kaba 1 yemek kaşık yağ (bitkisel yağ, ayçiçeği yağı veya zeytinyağı) dökün, üstüne patatesleri ekleyin ve patatesler yağ ile kaplanana kadar karıştırın.
4. Patatesleri parmaklarınızla veya maşa ya da kaşık gibi bir mutfak aleti ile yağ fazlası kasede kalacak şekilde alın. Patatesleri hazneye koyun.
Not: Yağ kaplı patateslerin olduğu kabı doğrudan tek seferde hazneye devirmeyin. Aksi takdirde fazla yağ haznenin dibine iner.
5. Patates dilimlerini Yemek Pişirme Kılavuzu bölümündeki talimatlara göre kızartın.

TEMİZLEME

Cihazı her kullanımdan sonra temizleyin.

Hazne yapışmaz kaplamaya sahiptir. Yapışmaz kaplamaya zarar verebileceğinden temizlemek için metal mutfak aletleri veya aşındırıcı temizlik malzemeleri kullanmayın.

1. Elektrik fişini, duvardaki prizden çıkarın ve cihazı soğumaya bırakın.

Not: Cihazın daha hızlı soğuması için hazneyi çıkarın.

2. Cihazın dışını nemli bir bezle silin.
3. Hazneyi biraz bulaşık deterjanı ve aşındırıcı olmayan süngerle temizleyin. Kalan kirleri temizlemek için yağ giderici bir sıvı kullanabilirsiniz.
Not: Kase bulaşık makinesinde yıkanabilir.
İpucu: Haznenin ve ızgaranın dibine kir yapmışsa bunları sıcak su ve biraz bulaşık deterjanı ile doldurun. Hazne ve ızgaranın yaklaşık 10 dakika beklemesine izin verin. Sonra durulayarak temizleyin ve kurulaşın.
4. Cihazın içini sıcak su ve nemli bir bezle silin.
5. Isıtma elemanındaki mevcut gıda artıklarını temizlemek için kuru bir temizlik fırçası kullanın.
6. Cihazı suya veya başka bir sıvıya batırmayın.

DEPOLAMA

1. Cihazı prizden çekin ve soğumaya bırakın.
2. Tüm parçaların temiz ve kuru olduğundan emin olun.

GARANTİ VE SERVİS

Hizmete veya bilgiye ihtiyacınız ya da bir sorunuz varsa lütfen markanın web sitesini ziyaret edin veya markanın ülkenizdeki Müşteri Hizmetleri Merkezi ile iletişime geçin. Telefon numarasını dünya çapında geçerli garanti belgesinde bulabilirsiniz. Ülkenizde Müşteri Hizmetleri Merkezi yoksa yerel marka bayinize gidin.

SORUN GİDERME

Cihazla ilgili sorunlarla karşılaşırsanız sık sorulan soruların listesi için markanın web sitesini (Bu kılavuzun kapak sayfasına bakın) ziyaret edin veya ülkenizdeki Müşteri Hizmetleri Merkezi ile iletişime geçin.

1820013535